

Chelino

6m+/3y | < 15kg

EN 14988: 2017+ A1: 2020

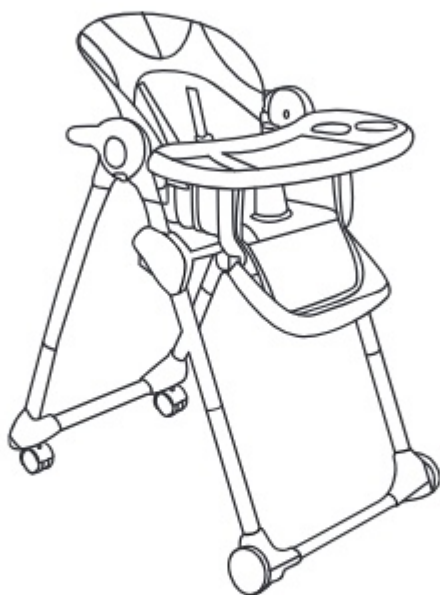

CLOUD II

CHELINOBABY GROUP OF COMPANIES.
NO. 12 KIMBERLITE ROAD, THETA EXT 5,
BOOYSENS RESERVE, JHB, 2091.SA.
Tel: +2711 8352520

www.chelinobaby.co.za



Check that you have all the below parts for this model before assembling the product.



1.Seat Unit (1x)

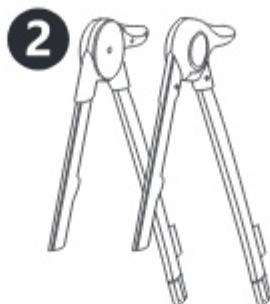

2.support upper part



3.Front feet



4.Rear feet



5.Two part serving tray

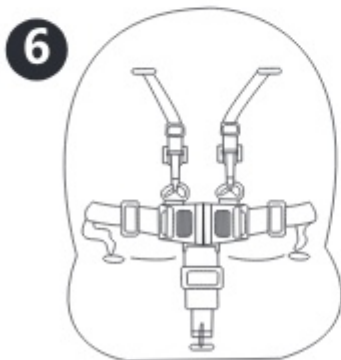

6.Seat Cover+Safety harness

Use the 5-point harness at all times to ensure that baby is safe and secure while seated.

- 1.Place the baby in the seat
- 2.Attach shoulder straps to waist belt.
- 3.Position the crotch strap between baby's legs and feed arms through shoulder straps
- 4.Close buckles. You should hear a "Click" sound.
- 5.Adjust sliders for a snug fit (readjust as baby grows).
- 6.Check to be sure the harness is securely attached by pulling it away from baby; it should remain attached.



1. Take the support upper part insert to the seat unit.



2. Take the front feet insert to the seat unit.



3. Take the rear feet insert to the seat unit.



4. Outward pull the button on the tray bottom and move to the desired position. Tray has 3 positions.



Height adjustment

1. There are 6 positions for height adjustment.
2. Both hands press the button (as picture), to move up and down to the desired position.



Seat Back Adjustment

1. The vertical state of the seat back is only suitable for children who more than 6 months.
2. Hold the button on the back and pull up like picture at the same time then pull back.



Folding the high chair

1. Press the button (A) on both sides at the same time, lower the seat of the high chair to the lowest position.
2. Press the button beneath the arms rest (B) on both sides at the same time, and slide the rear legs forward.

SAFETY WARNING

- Never leave our child unattended.
- Always use the restraint system.
- Falling hazard: Prevent your child from climbing on the product.
- Do not use the product unless all components are correctly fitted and adjusted.
- Be aware of the risk of open fire and other sources of strong heat in the proximity of the product.
- Be aware of tilting danger when your child can get a foothold on a table or any other structure.
- Do not use the product until if parts are broken, torn or missing. Any additional harness other than that provided by the manufacturer must comply with EN 13210.
- Keep children away from the product when folded or unfolded to avoid injury.
- The product is intended for children able to sit up unaided and up to 3 years or a maximum weight of 15 kg.
- Warning! Children's chair/table located under a window could be used as a step by the child and cause the child to fall out of the window.

Maintenance

Wash with a sponge and mild soap. Remember that all mechanical products need regular maintenance and careful use if they are to provide maximum satisfaction and last a long time.

Due to variation on the styles and designs of our products, the photographs and illustrations shown in this manual are generic. Therefore products fabric, colour and design may vary from images shown, Chelino reserves the right to alter products specifications.

DIMENSION INFO

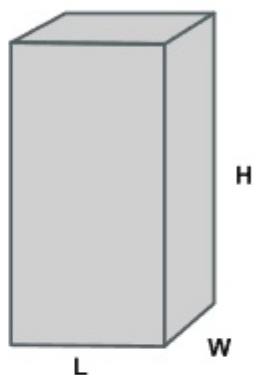

LENGTH	79 CM
WIDTH	60 CM
HEIGHT	108 CM

CARTON LENGTH	50.5 CM
CARTON WIDTH	30 CM
CARTON HEIGHT	66 CM

WEIGHT	7.6 KGS
--------	---------

SAFETY HINTS \ INSTRUCTIONS OF USE \ WARRANTY & GAURANTEE GUIDELINES

1. Please read this User Guide thoroughly before using this product. If you are not sure on any point in this guide please consult with the sales person whom sold you this product or contact Chelino on 0118352520. Our offices hours are Monday to Thursday from 9:00 am to 13:00 pm and 14:00 pm to 16:30 pm and Fridays from 9:00 am to 12:00 pm and 14:00 pm to 16:30 pm. Our offices are closed on Saturdays, Sundays, Public holidays and for three weeks during the December/ January festive season. We are situated at 12 Kimberlite Road, Theta Ext, Booyens Reserve, 2091, Johannesburg, Gauteng, RSA.
2. To avoid suffocation or swallowing or any other illness, please keep all packaging which have been removed from parts wrapped in the box away from infants, toddlers, children or any other living being. Please carefully dispose of the unwanted packaging once this product is fully assembled and you are satisfied with your purchase.
3. Please make sure that you are entirely satisfied with your purchase before removing the warning card attached to this product and before using this product. Once the warning card has been removed and if this product has been used we will not accept the return of this product.
4. If you are not entirely satisfied with this product purchased, please disassemble this product and re-pack it in the original packaging and return it to the store you purchased it from together with the proof of purchase. Depending on the stores policy, you will either be entitled to a replacement product, a credit voucher or a refund. This depends on the stores policies.
5. If you are not entirely satisfied with the assemble of this product or if you are not 100% sure that you have assembled this product correctly, please take this product back to the store you purchased it from and request for some assistance in checking if the assembly is correct or get this product assembled. Depending on the store's policy, there could be an extra charge for this service. Chelino will not take any responsibility if this product is incorrectly assembled thus causing any sort of injury to the user or the child. Alternatively you can contact Chelino directly on 0118352520, our offices hours are Monday to Thursday from 9:00 am to 13:00 pm and 14:00 to 16:30 pm and Fridays from 9:00 am to 12:00 pm and 14:00 pm to 16:30 pm. Our offices are closed on Saturdays, Sundays, Public holidays and for three weeks during the December/ January festive season. There is a charge for the assembly of any product. If you require a Chelino representative to assemble this product you will have to bring this product to our offices which are situated at 12 Kimberlite Road, Theta Ext, Booyens Reserve, 2091, Johannesburg, Gauteng, RSA.
6. Please note, that any repair which will needs to be made to this product must be done at the Chelino workshop which is situated at 12 Kimberlite Road, Theta Ext, Booyens Reserve, 2091, Johannesburg, Gauteng, RSA. Our offices hours are Monday to Thursday from 9:00 am

to 13:00 pm and 14:00 pm to 16:30 pm and Fridays from 9:00 am to 12:00 pm and 14:00 pm to 16:30 pm. Our offices are closed on Saturdays, Sundays, Public holidays and for three weeks during the December/January festive season. We do not provide any loan\courtesy products while your product has been sent in for repairs. Chelino requires 7 working days to repair any product, but this lead time may vary depending on the transportation of the product too and from yourself. Once the warranty card is detached from this product and once this product is used even if used once and if there is a fault, this product will need to be sent to the Chelino Workshop for the repair and no refund\credit\exchange will be allowed. Only a Chelino representative can decide whether the product needs to be replaced\credited\exchanged.

7. Once you are satisfied with the assembly of this product and have read this instruction and agree to the terms stated and are ready to use this product, please ensure that all safety locks are engaged to ensure safe use of this product.

8. Please ensure that the child is always securely strapped into this product at all times. The seat belts must be properly adjusted to keep the child secured. If the seat belt is too loose the child could fall out thus causing injury. If the seat belts are too tight it will cause injury and aggravation to the child.

9. Never leave the child unattended or without parent\guardian supervision while in this product, as injury could be caused by other parties intentionally or unintentionally. This product can be knocked over and the child can be injured.

10. Never lift this product while the child is in it. This can cause injury to the child seated in this product.

11. Never allow the child to stand on the seat of this product. This can cause this product to fold and thus causing injury to the child. The child can also fall out of this product causing injury to him\herself. This can also cause damage to structure of this product.

12. This product is designed for the use of only one child. This product cannot accommodate more than one child.

13. Take special care when adjusting the backrest if the child is seated in this product. It is preferred to select the desired backrest position before seating the child in this product.

14. Front tray is there for convenience and are not suitable for holding large amounts of liquids (hot or cold) or heavy objects. These areas are also not waterproof or leak proof and spillage can occur.

15. This product is fit to carry a child weighing no more than 15kgs. It is suitable from 6 months to 3 years old.

16. Do not place this product near to a window or fire or heating equipment, it will cause danger.

17. Chelino takes no responsibility and will not be held liable for any damage or injury caused by using this product or if this product is used for any other purposes other than its intended purpose.

18. Please note, there are no warranties or guarantee on any fabrics or sponge grip handles used on this product.

ChelinoBaby®

Stores: ChelinoBaby – Ormonde – JHB
ChelinoBaby – Fourways – JHB
ChelinoBaby – Woodmead Square – JHB
ChelinoBaby – Greenstone – JHB
ChelinoBaby – Centurion – Pretoria
ChelinoBaby – Menlyn – Pretoria
ChelinoBaby – Kolonnade – Pretoria
ChelinoBaby – Gateway – Durban
ChelinoBaby – Cavendish Square – Cape Town
ChelinoBaby – Online – www.chelinobaby.co.za



Imported for :

ChelinoBaby Group of Companies.

No. 12 Kimberlite Road , Theta Ext 5 ,
Booyens Reserve , JHB , 2091. SA.

Tel: +2711 8352520

Info: info@chelino.co.za