

# ChelinoBaby®

Stores: ChelinoBaby – Ormonde – JHB  
ChelinoBaby – Fourways – JHB  
ChelinoBaby – Woodmead Square – JHB  
ChelinoBaby – Greenstone – JHB  
ChelinoBaby – Menlyn – Pretoria  
ChelinoBaby – Kolonnade – Pretoria  
ChelinoBaby – Centurion – Pretoria  
ChelinoBaby – Gateway – Durban  
ChelinoBaby – Online – [www.chelinobaby.co.za](http://www.chelinobaby.co.za)



Imported for :  
ChelinoBaby Group of Companies,  
No. 12 Kimberlite Road , Theta Ext 5 ,  
Booysens Reserve , JHB , 2091. SA.  
Tel: +2711 8352520  
Info: [info@chelino.co.za](mailto:info@chelino.co.za)



## Chelino



**SHUTTLE STAGES  
INSTRUCTION MANUAL**

**0-36kg 0+/I/II/III**

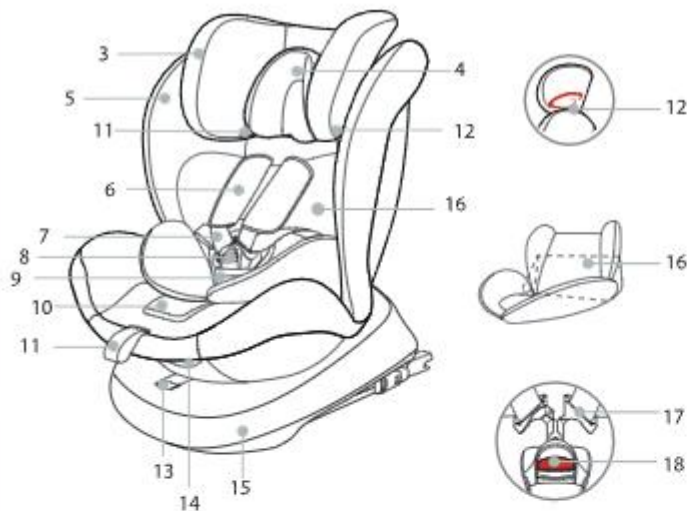

**WARNING!**

Read the instructions carefully before use and keep for future reference.

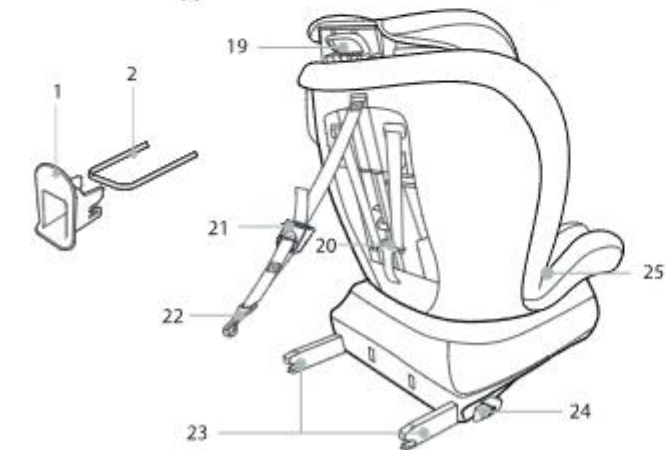

- 1 ISOFIX Insertion Aids
- 2 ISOFIX Fastening Points(vehicle)
- 3 Headrest
- 4 Head support
- 5 Seat Cover
- 6 Shoulder Pads
- 7 Shoulder Straps
- 8 Harness Buckle
- 9 Crotch Pad
- 10 Adjustment Button
- 11 Adjustment Strap
- 12 Belt Guidance
- 13 360° Rotation Adjuster
- 14 Recline Handle
- 15 Base
- 16 Seat Reducer
- 17 Buckle Tongues
- 18 Red Release Button
- 19 Headrest Height Adjuster
- 20 Shoulder Straps Connector
- 21 Top Tether Adjuster
- 22 Top Tether Clip
- 23 ISOFIX Locking Arms
- 24 ISOFIX Buttons
- 25 Belt Guidance

## 1. ISOFIX

1.1



1.2



1.3

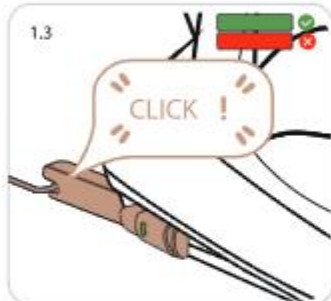

1.4



## 2. ROTATION

2.1

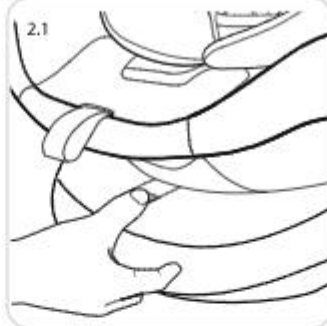

2.2



## 3. SEAT ANGLE

3.1



3.2

Fifth Level  
(Lying Level)  5





First Level



Second Level



Third Level



Fourth Level



## 4. PUT THE CHILD IN

4.1

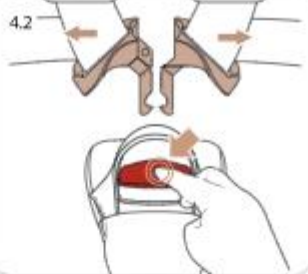
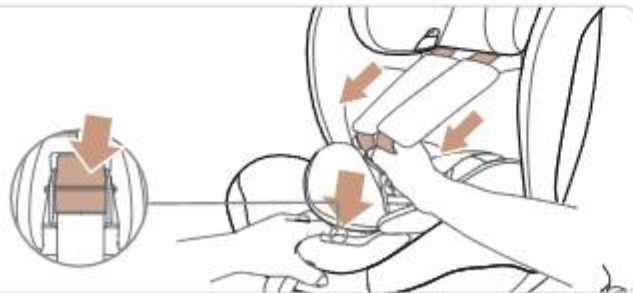

4.4

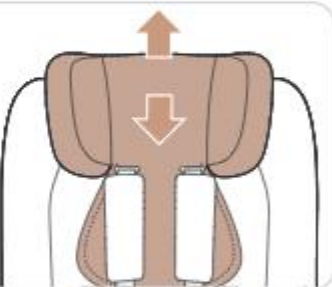
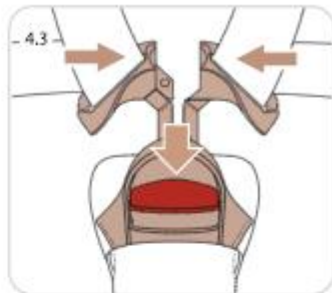

4.5



4.6

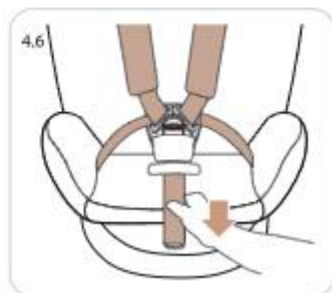

## 5. STORE 5-POINT HARNESS

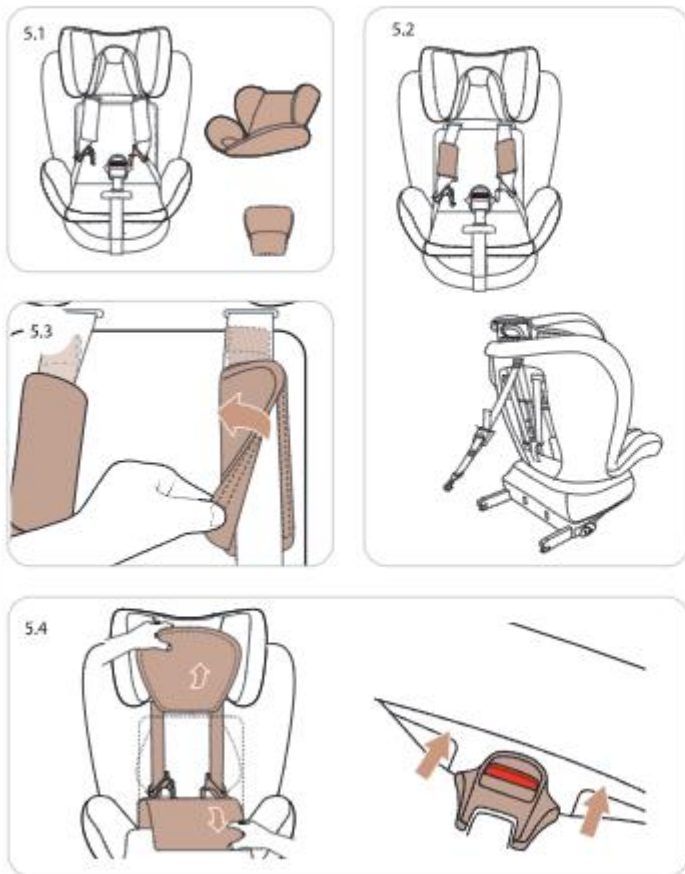

## 6. REARWARD FACING (0-13KG) INSTALLATION

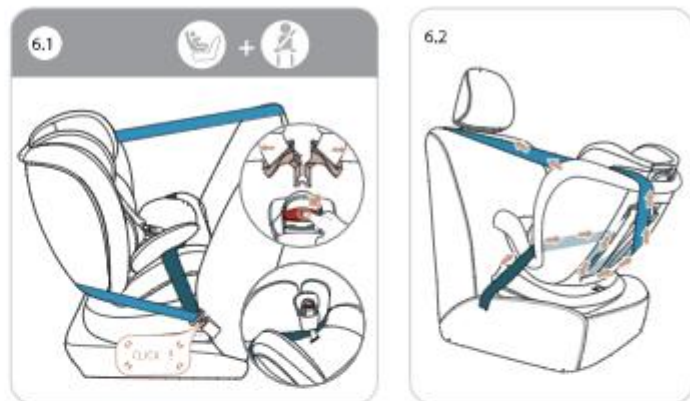

## 7. REARWARD FACING (0-18KG) INSTALLATION

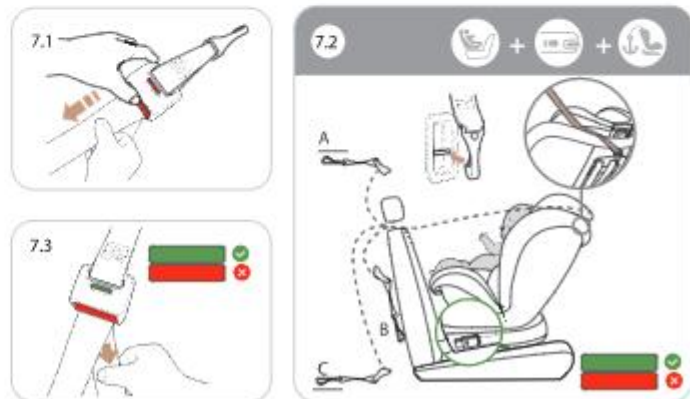





9.2



## 10. REMOVE HARNESS BUCKLE

10.1



10.2

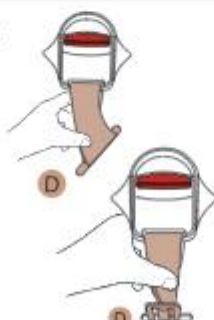

## APPROVAL

These instructions use the following symbols:

Symbol	Keyword	Explanation
	DANGER!	RISK of severe personal injury
	WARNING!	RISK of minor personal injury
	CAUTION!	RISK of material damage
	TIP!	Useful notes

The 946 CRS is exclusively intended to secure your child in your vehicle.

Tested and approved according to ECE R44/04

Body Weight	Installation method	Installation direction
0+(0-13kg)	Belt	Rearward facing
0+I(0-18kg)	ISOFIX+Top Tether	
I(9-18kg)	Belt	Forward facing
	Belt + ISOFIX	
II III(15-36kg)	Belt	
	Belt + ISOFIX	
	Belt + ISOFIX +Top Tether	

\*ECE=European Standard for Child Safety Equipment

The child safety seat has been designed, tested and approved according to the requirements of the European Standard for Child Safety Equipment (ECE R44/04). The seal of approval "E" (in a circle) and the approval number are located on the orange approval label (sticker on the child safety seat).

**DANGER!** This certification will be invalidated if you make any modifications to the child safety seat. Only the manufacturer is permitted to make modifications to the child safety seat. Unauthorised technical changes can cause the protective function of the seat to be reduced or completely eliminated.

Do not make any technical changes to the child safety seat.

**⚠ DANGER!** Use the SHUTTLE STAGES CRS exclusively for securing your child in your vehicle. It is in no way suitable for using as a seat or toy in the home.

## USE IN THE VEHICLE

Please observe the instructions for using Child Restraint Systems (CRS) in the vehicle handbook. During use, be sure to observe any restrictions relating to airbags. Please refer to the vehicle handbook information about vehicle seats which are certified for the use of children's restraining systems according to ECE R16.

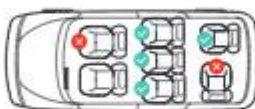

- Ⓐ Vehicle belt—Diagonal Belt
- Ⓑ Vehicle belt—Lap Belt
- Ⓒ ISOFIX Fastening Points
- Correct/Proper
- Wrong/Improper

When using as Universal category (Group 0+ I II III), This child restraint system is suitable for models equipped with a 3-point vehicle belt that complies with ECE R16 and does not apply to models only equipped with 2-point seat belts.

When using as Semi-Universal category (Group 0+I II III), This child restraint system is suitable for models equipped with the 3-point vehicle belt that has passed the ECE R16 requirement and is not suitable for models only equipped with 2-point seat belts. And only after installed ISOFIX, then can use on it.

(Please observe the applicable regulations in force in your country)

1. Facing backwards (against the direction of travel) 0-18kg: Do not use on passenger seats with an active front airbag!
2. Facing forwards (in the direction of travel) 9-36kg: If there is a passenger airbag: Slide the passenger seat well backwards and follow

any relevant directions in your vehicle handbook, please ensure that the airbag is deactivated.



### WARNING!

Do not use facing forwards before the child's weight exceeds 9kg (refer to instruction).

## 1. ISOFIX

- 1.1 If your vehicle is not fitted with ISOFIX insertion aids as standard, clamp the two ISOFIX insertion aids (1), which are included in the scope of delivery of the seat, with the opening pointing upwards, to the two ISOFIX fastening points (2) of your vehicle. If you don't have ISOFIX insertion aids (1), please ignore this step.



**TIP!** The ISOFIX fastening points are located between the surface and the backrest of the vehicle seat.

- 1.2 Press the ISOFIX buttons (23) to push out the two ISOFIX locking arms (22) from the seat base.
- 1.3 Push back the child safety seat until the child safety seat is rest firmly against the vehicle seat then you hear a clicking sound which indicates they are fully engaged. And on both sides of the ISOFIX indicator from red to green safety color.
- 1.4 Move the child safety seat backwards and push the backrest against the vehicle seat.



**TIP!** Release button towards each other to loosen the ISOFIX fastening point on both sides. Move the ISOFIX locking arms back into the seat base, it can protect ISOFIX.

## 2. ROTATION



- 2.1 Press the 360° rotation adjuster (12) with thumb, rotate the seat shell.
- 2.2 Rotate the seat shell so it is facing either forwards or backwards, depending on the weight of your child, until it engages with a clicking sound.



**TIP!** When installed in forward facing position with belt or belt+ISOFIX (9-18kg), function of rotation may be restricted.



### **DANGER!**

When the seat is rotated to 90°, the user can place the child in this position, but he/she can not use this angle during driving.

## 3. SEAT ANGLE

The seat shell of the SHUTTLE STAGES CRS can be used in 4 different reclined positions facing forwards and in fifth level position facing backwards:

- 3.1 Pull the recline handle (13) up, then the seat can be adjusted.

It can be adjusted to 4 positions for forward facing use.

When the seat is in the position of fourth level, rotate the seat to the rearward direction, and the seat can be adjusted to fifth level.

- 3.2 0-18kg: rearward facing installation, use fifth level.
- 3.3 9-18kg: forward facing installation, use first level to fourth level.  
15-36kg: forward facing installation, use first level.

## 4. PUT THE CHILD IN

- 4.1 Loosen the shoulder straps (6) by pressing the adjustment button (9) and pull both shoulder straps forwards, loosen it as much as possible.

- 4.2 Press red release button (17) to open the harness buckle (7). Place child in child safety seat.
- 4.3 Bring both buckle tongues (16) together. Lock buckle tongues in harness buckle (7), until they engage with a clicking sound.
- 4.4 Pull the headrest height adjuster (18), select the correct height of the headrest (3) and engage it in position that fits your child by releasing the adjuster.
- 4.5 Adjust the headrest (3) to proper position. Make sure the distance between child's shoulder and the bottom of the headrest is lower than one finger.
- 4.6 Pull the adjustment strap (10) until the strap lies flat and snug on your child's body. Make sure that the shoulder straps slightly higher or equal to child's shoulders.

**WARNING!** Before each car journey, in order to ensure your child's safety, make sure that...

- The child safety seat is fastened in the ISOFIX fastening points (2) on both sides with the ISOFIX locking arms (22) and both ISOFIX buttons (23) are fully green;
- The child safety seat is securely fastened;
- The harness of the child safety seat is fitted snugly to the child's body without being constricting and should not be twisted;
- The shoulder straps (6) are correctly adjusted and the straps are not twisted;
- The shoulder pads (5) are in the correct position on your child's body;
- The front airbag is deactivated if you are using the child safety seat facing forwards on the passenger seat;
- The child safety seat is facing in the right direction for your child's age/weight;
- The buckle tongues (16) are inserted into the harness buckle (7).



### **DANGER!**

If your child tries to open the ISOFIX buttons or the red release button, stop immediately. Check whether the child safety seat is correctly fastened and ensure that your child is correctly secured. Explain to your child the dangers associated with their actions.

## 5. STORE 5-POINT HARNESS

Once the child reaches a weight of 15kg, the 5-point safety harness should be stored away and the child should be secured with the vehicle belt.

- 5.1 Open the harness buckle (4.2) as shown. Remove seat reducer (15) and crotch pad (8).
- 5.2 Loosen shoulder straps (6).
- 5.3 Tear off the velcro and remove the shoulder pads (5).
- 5.4 Open seat cover (4).  
Hide shoulder straps (6) and buckle tongues (16) under the cover and hide the harness buckle (7) to the storage.



### **WARNING!**

When your child's weight exceed 8kg, remove the triangle pad.  
When your child's weight exceed 12kg, remove the seat reducer.

### Reattach the 5-point harness:

Follow the steps for <store 5-point harness> in reverse order.

## 6. REARWARD FACING (0-13KG) INSTALLATION

Install the child safety seat with BELT

- 6.1 Pull out the vehicle belt and lock into the vehicle seat buckle, with the diagonal belt bypasses the rear of the seat. Remain the diagonal belt in same place and the upper part goes through the gap between headrest and backrest. Open the harness buckle with the lap belt goes between the seat reducer(15) and backrest.



**TIP!** When the child safety seat is installed in rearward facing, the path of the lap belt has the same blue guide on the cloth cover.

- 6.2 Tighten the vehicle belt in the direction of arrow as shown, adjust the lap belt first, then the diagonal belt, which must pass between the headrest and the backrest. Ensure the vehicle belt is not twisted.



### **WARNING!**

To make sure that the vehicle seat has been installed correctly, please shake it before use. If shaking or loosening is found, you must retighten the vehicle belt until the safety seat is stable. The vehicle belt must not be twisted after installation.

## 7. REARWARD FACING (0-18KG) INSTALLATION

Install the child safety seat with ISOFIX + TOP TETHER

Install the child safety seat with ISOFIX (refer to page 14) (1.2) (1.3).

- 7.1 Pull out the top tether, by pressing the top tether adjuster (20) button.
- 7.2 Pull the top tether long enough to hang the top tether clip (21) on the fixed point, which on the back of the vehicle seat, the position of the fixed point are shown in the picture (one of the A/B/C positions).

Make sure the top tether goes through the gap between headrest (3) and backrest.

- 7.3 Make sure the top tether strap is tightened up and make sure the top tether adjuster (20) indicator turn into green safety color.

## 8. FORWARD FACING (9-18KG) INSTALLATION

Install the child safety seat with BELT or BELT + ISOFIX

Install the child safety seat with ISOFIX (refer to page 14) (1.2)(1.3).

If you don't have ISOFIX, please ignore this step. Install the child safety seat with vehicle belt.

- 8.1 Pull out the belt from the belt ALR (Automatic Locking Retractor). Diagonal belt pass through the gap between the headrest and backrest, then pull the diagonal belt and lap belt together through the other side guidance (24) on the seat base.



**TIP!** When installed in forward facing, the path of the lap belt has the same red guide on the cloth cover.



### WARNING!

The vehicle belt must not be twisted or have their places changed over.

- 8.2 Lock the tip of the buckle into the vehicle seat buckle with a clicking sound. Follow the direction of arrow to tighten belt, and put redundant belt into ALR. Shake the child safety seat to make sure it is securely attached.



**TIP!** The diagonal vehicle seat belt section must run diagonally backward. You can adjust the course of the belt with your vehicle's ALR on both sides.

## 9. FORWARD FACING (15-36KG) INSTALLATION

Store 5-point harness

(Refer to page 17 )<store 5-point harness>

Install the child safety seat with only BELT or BELT + ISOFIX or BELT + ISOFIX + TOP TETHER

Install the child safety seat with ISOFIX (refer to page 14)(1.2)(1.3). If you don't have ISOFIX, please ignore this step. Install the child safety seat with vehicle belt.

- 9.1 Pull out the belt from the belt ALR (Automatic Locking Retractor). Diagonal belt through the same side of guidance (11) on headrest, then pull the diagonal belt and lap belt together through the other side guidance (24) on the seat base.

If you want to use top tether + belt + ISOFIX, can refer page 14 (1.2) (1.3), page 18 (7.1) (7.2) (7.3).



**TIP!** Keep the diagonal belt at the position of belt guidance between the outside of the neck and shoulder (in the middle of point and point ).



### WARNING!

The vehicle belt must not be twisted or have their places changed over.



**TIP!** The importance of ensuring that any lap vehicle seat belt is worn low down, so that the pelvis is firmly engaged, shall be stressed.

- 9.2 Lock the tip of the buckle into the vehicle seat buckle with a clicking sound. Follow the direction of arrow to tighten belt, and put redundant belt into ALR. Shake the child safety seat to make sure it is securely attached.



**TIP!** The diagonal vehicle seat belt section must run diagonally backward. You can adjust the course of the belt with your vehicle's ALR on both sides.

## 10.REMOVE HARNESS BUCKLE

Open the harness buckle (4.2) as shown. Remove crotch pad (8).

10.1 Lift up the seat cover, pull down harness buckle (7) across seat cover (4).

10.2 Rotate the metal plate on crotch straps by 90° vertically, then harness buckle (7) can take out from slot (D).

To re-install harness buckle (7) follow the steps refer to (10.2) in reverse order, until the metal plate is hooked into the harness slot. Thread the harness buckle (7) through the crotch pad (8) on the cover. Make sure the metal plate under slot (D) when you are using.



### CAUTION!

Tug hard on the crotch strap to make sure that it is secure in the seat shell.

## CARE AND MAINTENANCE

### Child safety seat

Only use authentic SHUTTLE STAGES CRS seat covers. The seat cover is an integral part of the child safety seat and is key to ensure the trouble-free functionality of the system. Replacement seat covers are available from your dealer.

- The cover can be removed and washed with a mild detergent on a washing.
- The baby reducer can be washed in the same way as the cover. Remove all foam parts from the top and bottom sections before washing. These must not be washed.

- The shoulder pads can be removed and washed in lukewarm soapy water.
- The plastic parts and the harnesses can be cleaned with soapy water. Do not use any caustic cleaning agents (such as solvents).

### Harness buckle

To ensure the safety of your child, it is absolutely essential that the harness buckle continues to function correctly. Harness buckle malfunctions are usually caused by a build-up of soiling or by external objects:

- When you press the red release button (17), it takes a long time for the buckle tongues to be ejected.
- The buckle tongues (16) no longer engage (i.e. when you try to push them in, they pop out again).
- The buckle tongues (16) engage without a clicking sound.
- The buckle tongues (16) are difficult to push in (you feel a certain amount of resistance).
- The harness buckle (7) only opens if extreme force is applied.

Remedy: Soak the harness buckle (7) in warm water containing washing-up liquid for at least an hour. Rinse the buckle thoroughly and dry it.

## DISPOSAL

Please observe the waste disposal regulations in your country.

Disposal of packaging	Container for cardboard boxes
Seat cover	Residual waste, waste incineration
Plastic parts	To be placed in the corresponding container according to labelling
Metal parts	Container for metals
Belt straps	Container for polyester
Buckle and tongue	Residual waste



## SAFETY NOTES

### NOTICE

When using as Universal category (Group 0+ II III), please notice below information:

This is a "Universal" child restraint. It is approved to Regulation No. 44, 04 series of amendments, for general use in vehicles and it will fit most, but not all car seats.

A correct fit is likely if the vehicle manufacturer has declared in the vehicle handbook that the vehicle is capable of accepting a "Universal" child restraint for this age group.

This child restraint has been classified as "Universal" under more stringent conditions than those which applied to earlier designs which do not carry this notice.

If in doubt, consult either the child restraint manufacturer or the retailer.

When using as Semi-universal category (Group 0+ II III), please notice below information:

This child restraint is classified for "Semi-universal" use and is suitable for the seat positions of the following cars:

CAR (Model)	FRONT	REAR
		Outer
	Yes—	Yes— No

Seat positions in other cars may also be suitable to accept this child restraint. Please refer to the information documents or the retailer's website for the suitable car model list. If in doubt, consult either the child restraint manufacturer or the retailer any time.

Notice regarding ISOFIX Child restraint system (Group 0+ , I Rearward-facing):

1. This is an ISOFIX CHILD RESTRAINT SYSTEM. It is approved to the Regulation No.44,04 series of amendments, for general use in vehicles fitted with ISOFIX anchorages systems.
2. It will fit vehicle with positions approved as ISOFIX positions

(as detailed in the vehicle handbook), depending on the category of the child seat and of the fixture.

3. The mass group and the ISOFIX size class for which this device is intended is: D for Group 0+(0-13kg) and Group I(9-18kg).

### DANGER!

Please carefully read and make sure you understand all instructions in this manual and in the vehicle handbook relate to child safety seats. Install and use the child safety seat as described in the instruction manual. Failure to do this could result in serious injury even death of your child. Keep the instructions together with the CRS for future reference.

### DANGER!

Because of potential medical issues inherent to low birth weight and premature infants, always have a trained professional doctor or hospital staff assess the suitability of the CRS prior to leaving the hospital or using the CRS.

**MAKE SURE** any straps holding the CRS to the vehicle should be tight. Any straps restraining the child should be adjusted to the child's body. Make sure straps should not be twisted.

**MAKE SURE** in 15-36kg weight, the lap vehicle seat belt must be worn in such a way as to properly secure the pelvis of the child.

**MAKE SURE** the CRS is changed when it has been subject to violent stresses in an accident.

**MAKE SURE** the rigid items and plastic parts of a CRS shall be so located and installed that they are not liable, during everyday use of the vehicle, to become trapped by a movable seat or in a door of the vehicle.

**DO NOT** make any alteration or additions to the CRS without



the approval of the Type Approval Authority, or a danger occurs if not provided closely the installation instructions provided by the CRS manufacturer.

**HOT!** The child seat should be kept away from sunlight if the seat is not provided with a textile cover, otherwise it may be too hot for the child's skin.

**DO NOT** leave your child unattended in this restraint even for a short time.

**MAKE SURE** any luggage or other objects liable to cause injuries in the event of a collision shall be properly secured.

A) **DO NOT** use the CRS without the cover.

B) **DO NOT** replace seat cover with any other than the one recommended by the manufacturer. because the cover constitutes an integral part of the restraint performance.

**DO NOT** use the CRS if position of the vehicle seat buckle to the main load bearing points on the restraint is unsatisfactory, please contact the manufacturer in doubt about this point.

**DO NOT** use any load bearing points other than those described in the instructions and marked in the CRS, please contact the manufacturer if in doubt about this point.

**DO NOT** use forward facing before the child's weight exceeds 9 kg (refer to instruction).

When using as Universal category (Group 0+ I II III),

This child restraint system is suitable for models equipped with a 3-point vehicle belt that complies with ECE R16 and does not apply to models only equipped with 2-point seat belts.

## **⚠ WARNING!**

The safest place for your baby is the rear of your car. However, if you need to install the seat in the front passenger seat, please ensure that the airbag is deactivated.

Due to variation on the styles and designs of our products, the photographs and illustrations shown in this manual are generic. Therefore products fabric, colour and design may vary from images shown, Chelino reserves the right to alter products specifications.

## DIMENSION INFO



LENGTH	40,5 CM	CARTON LENGTH	45,5 CM
WIDTH	40 CM	CARTON WIDTH	46 CM
HEIGHT	77 CM	CARTON HEIGHT	82 CM
WEIGHT	6,4 KGS		