

Chelino

PLATINUM



URBAN RIDER

CHELINOBABY GROUP OF COMPANIES.

NO. 12 KIMBERLITE ROAD, THETA EXT 5, BOOYSENS RESERVE, JHB, 2091.SA.

Tel: +2711 8352520

www.chelinobaby.co.za



IMPORTANT:READ CAREFULLY AND KEEP FOR FUTURE REFERENCE.

WARNING! Never leave your child unattended.

WARNING! Ensure that all the locking devices are engaged before use.

WARNING! To avoid injury ensure that your child is kept away when unfolding and folding this product.

WARNING! Do not let your child play with this product.

WARNING! Always use the restraint system.

WARNING! Check that the pram body or seat unit or car seat attachment devices are correctly engaged before use.

WARNING! This product is not suitable for running or skating.

WARNING! This product is suitable for children from birth to 36 months.

Maximum weight of the child:22kg.

WARNING! Any goods carried in the basket should not exceed 3 kg.

WARNING! Don't carry additional children, bags, goods or accessories in the stroller except those recommended by the manufacture.

WARNING! Before making adjustments to the stroller, ensure that the child's body is clear of any moving parts.

WARNING! Child may slip into leg openings and strangle. Never use in reclined carriage positions.

WARNING! Do not allow the child to stand up on the seat.

WARNING! This stroller is designed for one child only.

WARNING! Any load attached to the handle and/ or on the back of the backrest and/ or on the sides of the vehicle will affect the stability of the vehicle.

WARNING! Do not use on escalators or stairs. Fold the stroller and carry it by hands.

WARNING! Always activate the brakes when stop the stroller, put or take off any accessories.

WARNING! Do not use the stroller near open fire, exposed flame, barbecue or heater.

WARNING! Do not use the stroller if any screws, nuts, bolts, etc. are missing or any component is damaged.

WARNING! Do not lift the stroller by the bumper bar it may disengage.

WARNING! Note that the fabric patterns and stroller accessories in this instruction may vary from the one you have purchased.

WARNING! Only replacement parts supplied or recommended by the manufacturer/ distributor shall be used.

WARNING! Always apply the brakes when the pushchair is stationary, and when placing and removing children.

This product complies with EN 1888-2:2018.

Care and maintenance

1.Fabric:sponge clean only with a mixture of water and mild detergent.

Do not iron. Do not bleach.

2.Periodically check for loose and broken parts.

3.Exposing the stroller to direct sunlight for long periods may cause fading.

4.If stroller are with air inflatable wheels check if the air pressure of the wheels is normal or not before using(the standards air pressure is 35 Psi or 241.325Kpa).

Stroller frame parts

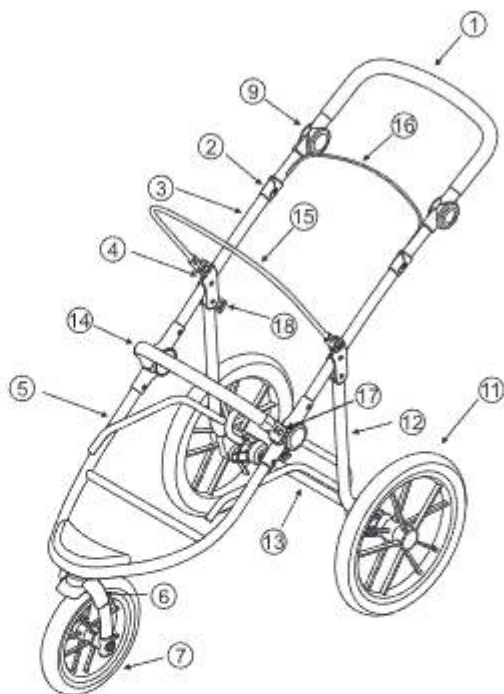
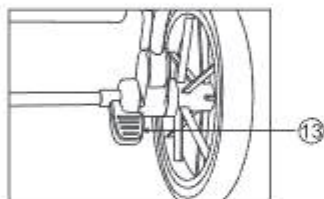
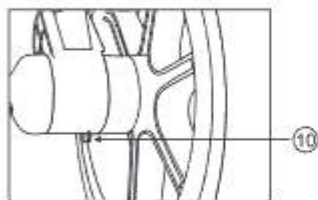
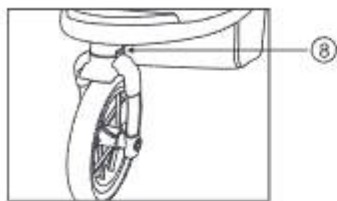

- | | | |
|-----------------------|-----------------------------|------------------------|
| 1. Handle grip | 9. Adjustable handle button | 14. Safety front bar |
| 2. Folding lever | 10. Rear leg tube | 15. Front canopy frame |
| 3. Handle tube | 11. Rear wheel | 16. Back canopy frame |
| 4. Canopy holder | 12. Rear leg tube | 17. Safety front bar |
| 5. Front leg tube | 13. Brake and release pedal | 18. Auto lock |
| 6. Front wheel socket | | |
| 7. Front wheel | | |
| 8. Directional lock | | |

To open the stroller frame

1. The status when it's folded.

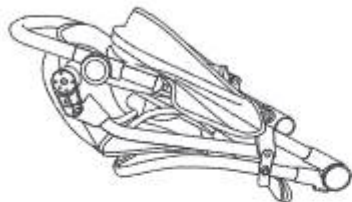

2. Release the folding hook as the picture shows.

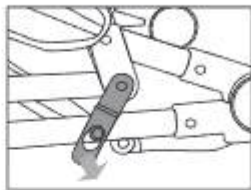

3. Hold the handles and lift upwards until the chassis is fully expanded.



4. The status when it's unfolded.



The front wheel orientation

To prevent the front wheels from swivelling, push the swivel locks backward (A).
To allow the wheels to swivel again pull the locks forward (B).

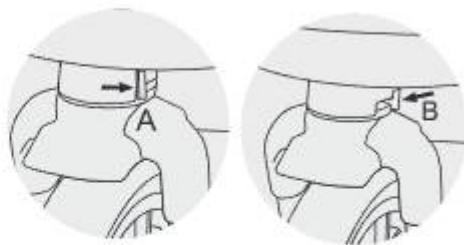
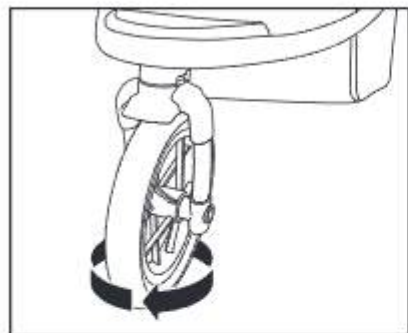

Rear wheel assembly

Insert the rear axle into the hole, until you hear a click sound. Ensure that it is engaged before use.

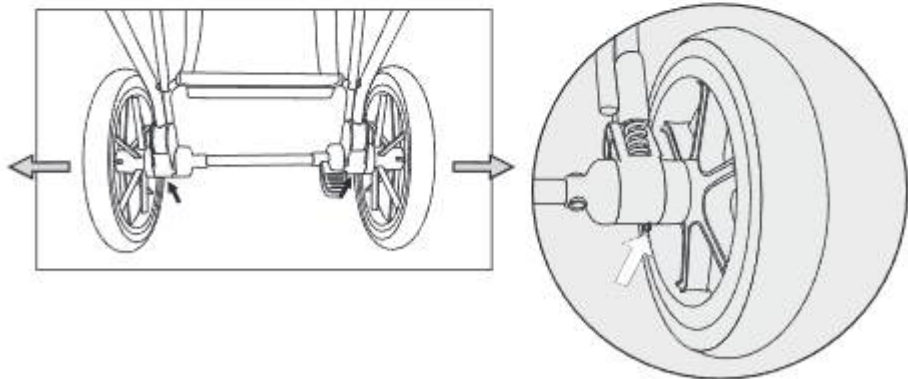

Rear wheel assembly

Insert the rear axle into the hole, until you hear a click sound. Ensure that it is engaged before use.

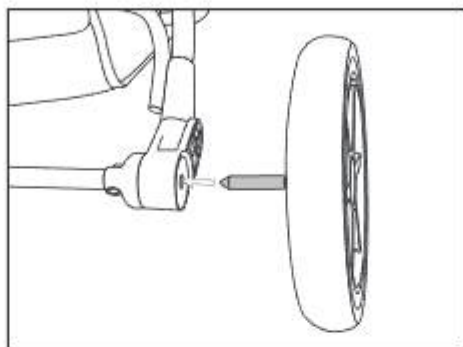

To use the brake

1. Step down the brake pedal until you hear a click sound to engage brake mechanism(A).
2. Step up the brake pedal to unlock the brakes(B).

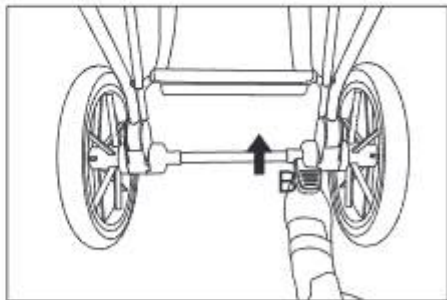
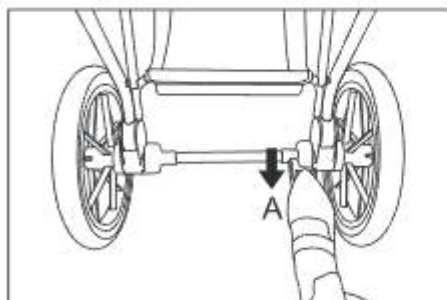

To use safety belts

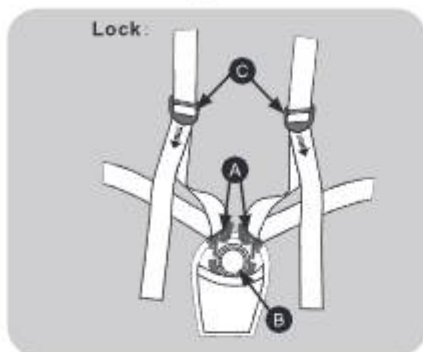

Lock the safety belt: insert the safety plug (A) into the safety socket (B) until it clicks into place. Adjust the ladder buckle (C) on the shoulder belt to make the harness fits snugly.

WARNING: Ensure harness is correctly fitted at all times.

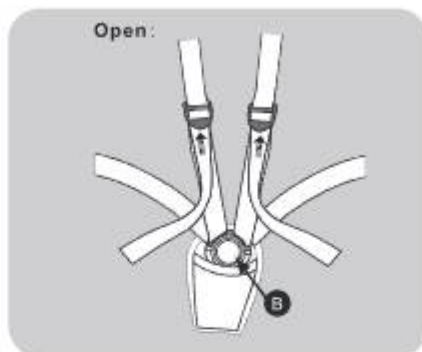

Release the seat belt: hold and press the top and bottom safety buckle seats (B) with your thumb and index finger. The harness fit can be adjusted using the ladder buckle (C) on the shoulder belt.

The shoulder strap could be adjusted as per child height requirement(see picture). To adjust the shoulder strap position further to the child, cross the strap to the middle or highest loop, to adjust the shoulder strap position closest to the child, cross the strap to the lowest loop.

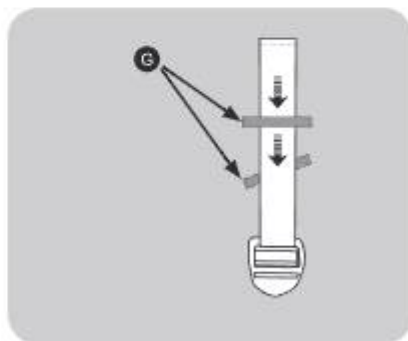

To use safety bar

WARNING: Install the safety bar before using.

Installing the bar: Line up both connectors on each side of the bumper bar and push downward to make it into the mounting bracket until they click in place.

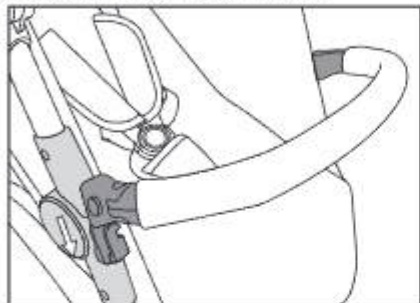

Releasing the safety bar: To remove, press both release buttons on the side of the mounting brackets and push the bumper bar upward.

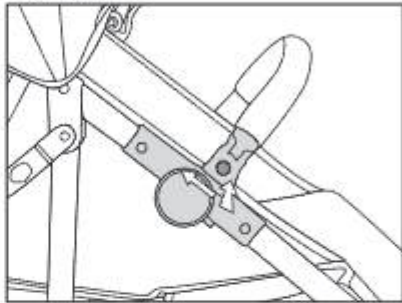

Backrest adjustment

Hold the button of the infinite adjustment, pull down lightly to adjust the height of the backrest.

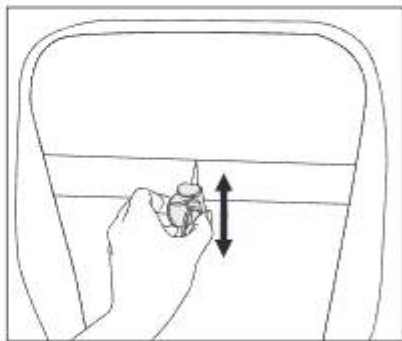

Adjust the handle

Pressing the adjustable handle button at the same time to operate different height of the handle (seven sections).

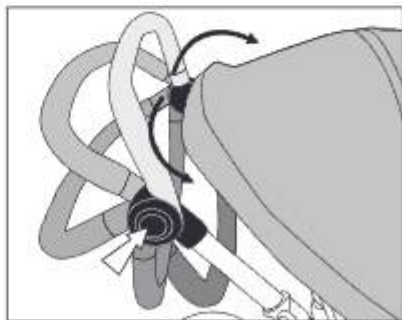

To fold the stroller

WARNING! To avoid injury ensure that your child is kept away when unfolding and folding this stroller.

1. Before folding the stroller, the backrest must be adjusted to lowest position.
2. Fold the canopy.
3. Hold and pull up the release button on both right and left side, push the handle downward until the stroller is folded down. Ensure the folding lock is secured.

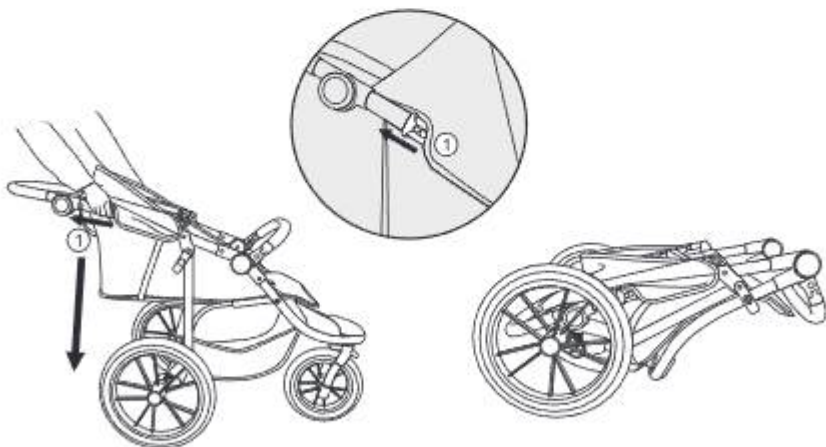

Collect and put stroller:

To minimize the volume of the folded stroller, make the adjustable handle into smallest section before folding.(show as A).

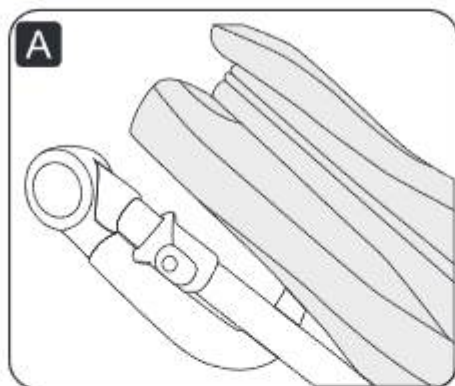
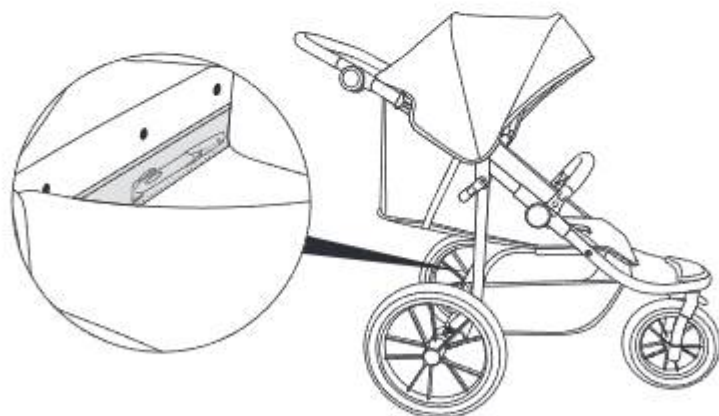
**Air pump storage pocket**

To fit the Maxi-Cosi adaptors

The adaptors are left and right specific and have an "L" and "R" printed on them. The left-hand adaptor (marked "L") MUST be placed into the left-hand mounting point of the chassis (as viewed from the front). The right-hand adaptor (marked "R") MUST be placed into the right-hand mounting point of the chassis. Make sure they have securely clicked in to place.

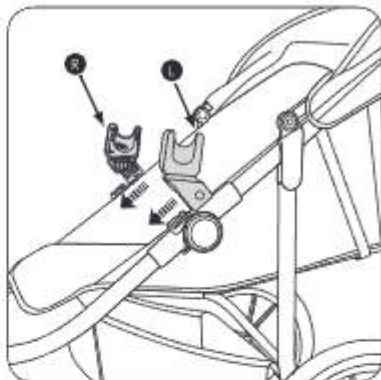

To remove the Maxi-Cosi adaptors

Press in release button and push off the adaptor from the chassis.

Important: Please refer to your car seat manufacturer's user guide for detailed instructions on attaching and removing your car seat.

Your car seat can only be fitted parent facing.

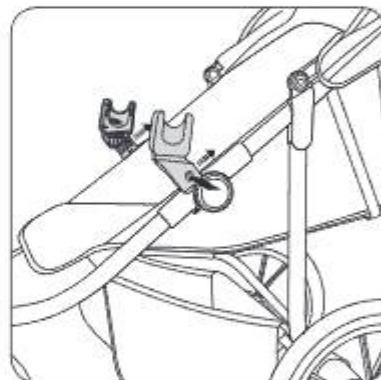

To fit the car seat onto the adaptors

Hold the car seat so that it is facing the stroller handle (parent facing). Position the car seat handle joints (A) above the adaptors (B) and push the seat downwards until it clicks into place.

Attention! Check attachment before using: Lift the car seat to ensure it is firmly attached to the stroller chassis.

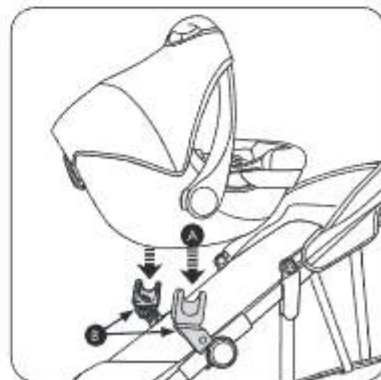

Use the raincover

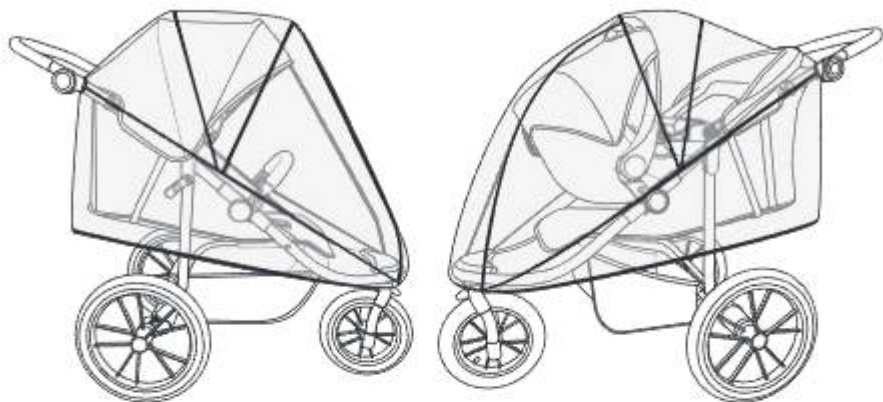

Due to variation on the styles and designs of our products, the photographs and illustrations shown in this manual are generic. Therefore products fabric, colour and design may vary from images shown, Chelino reserves the right to alter products specifications

Dimension Info



LENGTH	127 CM	FOLDABLE LENGTH	42 CM
WIDTH	61 CM	FOLDABLE WIDTH	61 CM
HEIGHT	112 CM	FOLDABLE HEIGHT	91 CM
WEIGHT	11.5 KG		

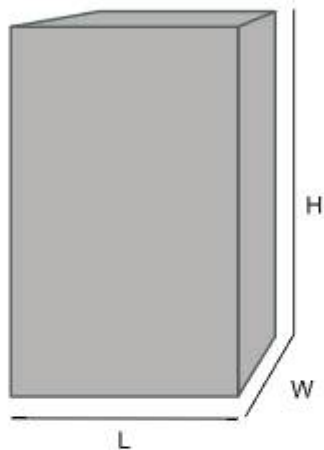

CARTON LENGTH	45 CM
CARTON WIDTH	36 CM
CARTON HEIGHT	76.5 CM

SAFETY HINTS \ INSTRUCTIONS OF USE \ WARRANTY & GAURANTEE GUIDELINES

1. Please read this User Guide thoroughly before using this product. If you are not sure on any point in this guide please consult with the sales person whom sold you this product or contact Chelino on 0118352520. Our offices hours are Monday to Thursday from 9:00 am to 13:00 pm and 14:00 pm to 16:30 pm and Fridays from 9:00 am to 12:00 pm and 14:00 pm to 16:30 pm. Our offices are closed on Saturdays, Sundays, Public holidays and for three weeks during the December/ January festive season. We are situated at 12 Kimberlite Road, Theta Ext, Booysens Reserve, 2091, Johannesburg, Gauteng, RSA.
2. To avoid suffocation or swallowing or any other illness, please keep all packaging which have been removed from parts wrapped in the box away from infants, toddlers, children or any other living being. Please carefully dispose of the unwanted packaging once this product is fully assembled and you are satisfied with your purchase.
3. Please make sure that you are entirely satisfied with your purchase before removing the warning card attached to this product and before using this product. Once the warning card has been removed and if this product has been used we will not accept the return of this product.
4. If you are not entirely satisfied with this product purchased, please disassemble this product and re-pack it in the original packaging and return it to the store you purchased it from together with the proof of purchase. Depending on the stores policy, you will either be entitled to a replacement product, a credit voucher or a refund. This depends on the stores policies.
5. If you are not entirely satisfied with the assemble of this product or if you are not 100% sure that you have assembled this product correctly, please take this product back to the store you purchased it from and request for some assistance in checking if the assembly is correct or get this product assembled. Depending on the store's policy, there could be an extra charge for this service. Chelino will not take any responsibility if this product is incorrectly assembled thus causing any sort of injury to the user or the child. Alternatively you can contact Chelino directly on 0118352520, our offices hours are Monday to Thursday from 9:00 am to 13:00 pm and 14:00 to 16:30 pm and Fridays from 9:00 am to 12:00 pm and 14:00 pm to 16:30 pm. Our offices are closed on Saturdays, Sundays, Public holidays and for three weeks during the December/ January festive season. There is a charge for the assembly of any product. If you require a Chelino representative to assemble this product you will have to bring this product to our offices which are situated at 12 Kimberlite Road, Theta Ext, Booysens Reserve, 2091, Johannesburg, Gauteng, RSA.
6. Please note, that any repair which will needs to be made to this product must be done at the Chelino workshop which is situated at 12 Kimberlite Road, Theta Ext, Booysens Reserve, 2091, Johannesburg, Gauteng, RSA. Our offices hours are Monday to Thursday from 9:00 am to 13:00 pm and 14:00 pm to 16:30 pm and Fridays from 9:00 am to 12:00 pm and 14:00 pm to 16:30 pm. Our offices are closed on Saturdays, Sundays, Public holidays and for three weeks during the December/ January festive season. We do not provide any loan/courtesy products while your product has been sent in for repairs. Chelino requires 7 working days to repair any product, but this lead time may vary depending on the transportation of the product too and from yourself. Once the warranty card is detached from this product and once this product is used even if used once and if there is a fault, this product will need to be sent to the Chelino Workshop for the repair and no refund/credit/exchange will be allowed. Only a Chelino representative can decide whether the product needs to be replaced/credited/exchanged.

7. Once you are satisfied with the assembly of this product and have read this instruction and agree to the terms stated and are ready to use this product, please ensure that all safety locks are engaged to ensure safe use of this product.
8. Please ensure that the child is always securely strapped into this product at all times. The seat belts must be properly adjusted to keep the child secured. If the seat belt is too loose the child could fall out thus causing injury. If the seat belts are too tight it will cause injury and aggravation to the child.
9. Never leave the child unattended or without parent/guardian supervision while in this product, as injury could be caused by other parties intentionally or unintentionally. This product can be knocked over and the child can be injured.
10. Never lift this product while the child is in it. This can cause this product to fold and thus causing injury to the child seated in this product. When confronted with a staircase, no matter how many steps there are, please use the alternatives such as an elevator/lift or ramp or remove the child from this product before using the staircase.
11. Never allow the child to stand on the seat of this product. This can cause this product to fold and thus causing injury to the child. The child can also fall out of this product causing injury to him/herself. This can also cause damage to structure of this product.
12. This product is designed for the use of only one child. This product cannot accommodate more than one child.
13. Always engage the brake when you are not using this product. Please note, by applying the brake one still cannot leave the child unattended and without parent supervision. If the brake is not engaged properly the product will move.
14. Take special care when adjusting the backrest if the child is seated in this product. It is preferred to select the desired backrest position before seating the child in this product.
15. Prevent and do not allow any child to climb into this product or hang onto the handle bars or any other part of this product. This imbalance of weight can cause this product to topple thus causing injury.
16. Do not hang or place any diaper bag or shopping bags or any other item over the handle bars or canopy of this product. This weight can cause damage to this product and also cause this product to fold or topple.
17. Storage trays/storage compartments/cup holders are there for convenience and are not suitable for holding large amounts of liquids (hot or cold) or heavy objects. These areas are also not waterproof or leak proof and spillage can occur.
18. The storage basket situated underneath the seat can hold a maximum weight of 2kgs. Do not place any items heavy than 3kgs and items which do not fit in this basket as this will hamper the performance of this product.
19. This product is fit to carry a child weighing no more than 22kgs.
20. This product was designed to be used on smooth surfaces and in average weather climates. Do not use this product on rough terrains and uneven surfaces and in extreme weather conditions. Using this product in the undesired terrains and weather conditions can cause serious damage to this product and to your child.
21. Chelino takes no responsibility and will not be held liable for any damage or injury caused by using this product or if this product is used for any other purposes other than its intended purpose.
22. Please note, there are no warranties or guarantee on any fabrics or sponge grip handles used on this product.

ChelinoBaby®

Stores: ChelinoBaby – Ormonde – JHB
ChelinoBaby – Fourways – JHB
ChelinoBaby – Woodmead Square – JHB
ChelinoBaby – Greenstone – JHB
ChelinoBaby – Centurion – Pretoria
ChelinoBaby – Menlyn – Pretoria
ChelinoBaby – Kolonnade – Pretoria
ChelinoBaby – Gateway – Durban
ChelinoBaby – Cavendish Square – Cape Town
ChelinoBaby – Online – www.chelinobaby.co.za



Imported for :

ChelinoBaby Group of Companies.

No. 12 Kimberlite Road , Theta Ext 5 ,

Booyens Reserve , JHB , 2091. SA.

Tel: +2711 8352520

Info: info@chelinoplatinum.co.za