

Chelino

PLATINUM



GEORGINA 4 IN 1 COT

CHELINOBABY GROUP OF COMPANIES,
NO. 12 KIMBERLITE ROAD, THETA EXT 5, BOOYSENS RESERVE, JHB, 2091.SA.
Tel: +2711 8352520

www.chelinobaby.co.za



BEFORE ASSEMBLING THIS GEORGINA 4 IN 1 COT, READ AND UNDERSTAND THE INSTRUCTIONS. INCORRECT ASSEMBLY MAY MAKE THE GEORGINA 4 IN 1 COT UNSAFE. DO NOT USE THIS PRODUCT IF ANY PART IS BROKEN, TORN OR MISSING. KEEP THIS INSTRUCTIONS IN A SAFE PLACE FOR FUTURE REFERENCE.

Safety & care notes

WARNING! Be aware of the risk of open fire and other sources of strong heat, such as electric bar fires, gas fires, etc, in the vicinity of the cot/bed.

WARNING! Do not use this product if any part is broken, torn or missing.

WARNING! Do not leave anything in the cot/bed, or place it close to another product which could provide a foothold or present a danger of suffocation or strangulation. For example strings, blind/curtain cords etc.

WARNING! Do not use more than one mattress in the cot.

WARNING! Do not place this child's bed near heat sources, windows or other furniture.

The lowest position of the mattress base is the safest, and should be used as soon as the baby is old enough to sit up.

The size of the mattress to be used with the cot bed is 132cm long by 66 cm wide and up to 10 cm in thickness.

The width and length are specified because it is important that the gaps between the mattress and the sides and the ends of the cot will not exceed 3cm.

Children are likely to play, bounce, jump and climb on beds, therefore the child's bed should not be placed too close to other furniture or windows, blind cords, curtain pulls or other strings or cords, and should be placed either tight to any wall or have a gap of 30cm between the wall and the side of the bed.

Always keep medication, string, elastic, small toys or similar small items out of reach from any position of the cot.

To prevent injury from falls, when the child is able to climb out of the cot, the cot shall no longer be used for that child.

All assembly fittings should be tightened properly, checked regularly and re-tightened as necessary.

If assembling as a cot, please ensure all remaining conversion fittings and instructions are kept for future use.

The cot/bed must be used on a level and stable surface, away from electric sockets. Never move the cot/bed with a child in it.

Once assembled do not dismantle for transportation or storage.

Excessive chewing may damage the wood and cause splintering.

Care of your product

Your cot/bed can be cleaned by wiping with a damp cloth and drying with a soft clean cloth.

Do not use abrasives, bleach, alcohol or ammonia based household polishes.

Take care when handling or moving.

Careless handling can damage wooden furniture.

Wood is a natural material, the colour will darken with age.

Parts check list



A
x2



B
x2



C



D
x2



E
x2



F
x2



G
x2



H
x2



I
x2

1



x8

2



x20

3



x12

4



x12

5



x2

6



x4

7



x4

8



Assembly diagram

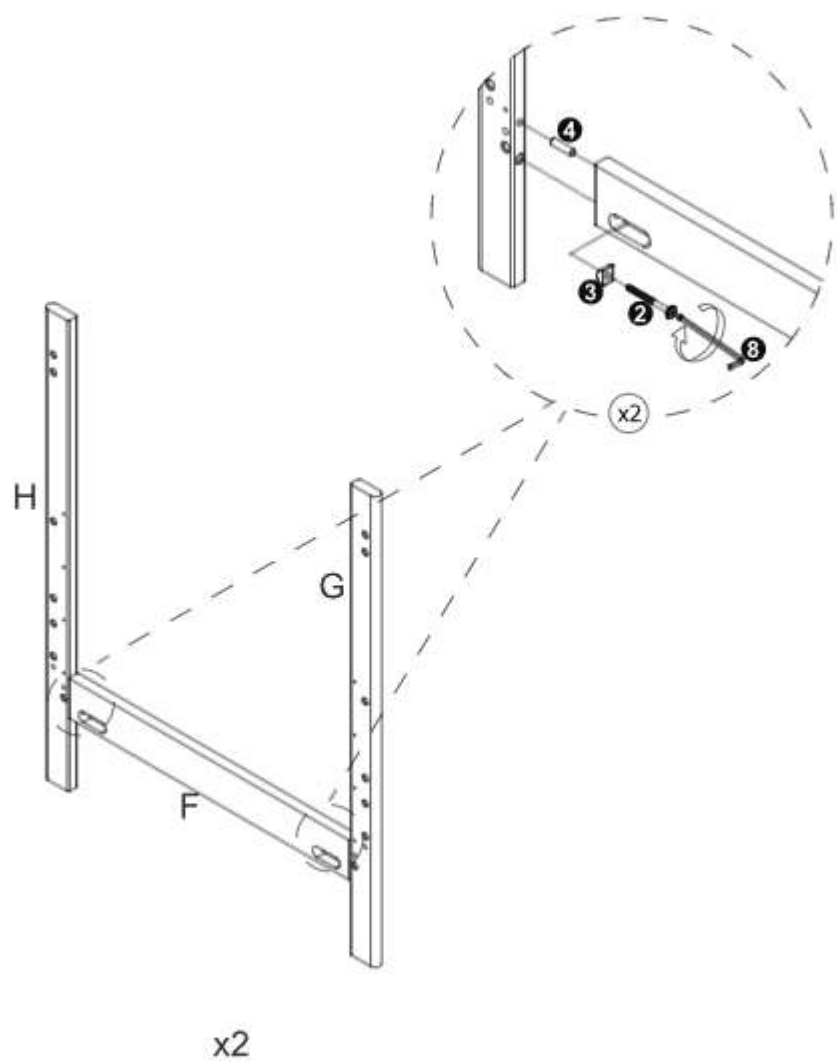

Assembly diagram

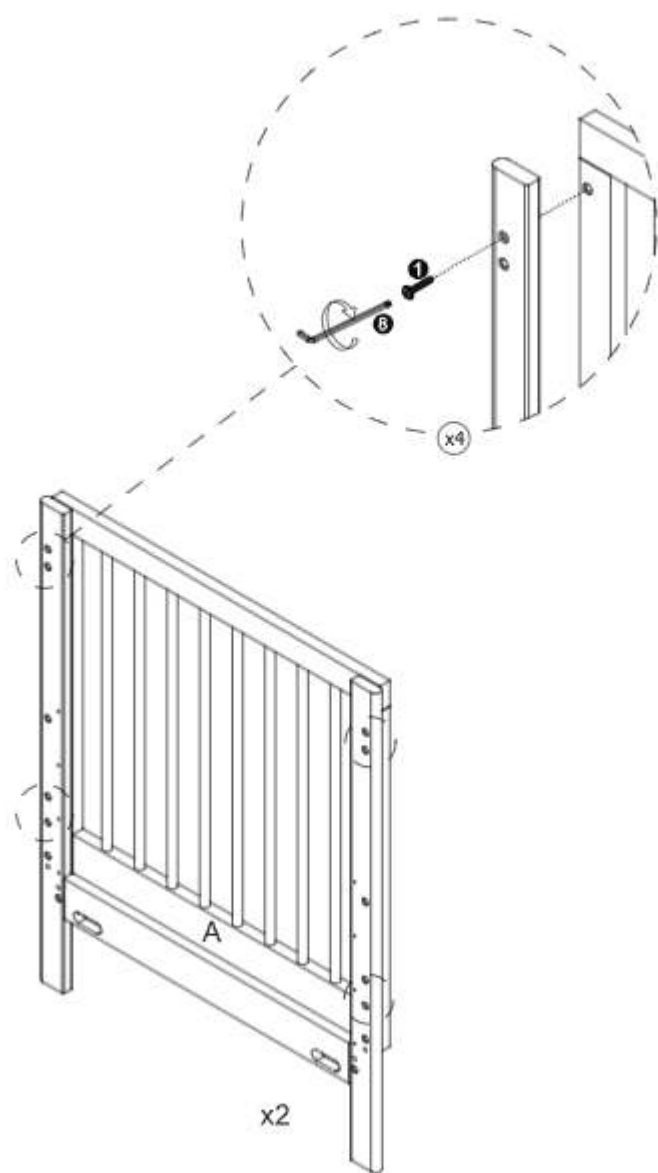

Assembly diagram

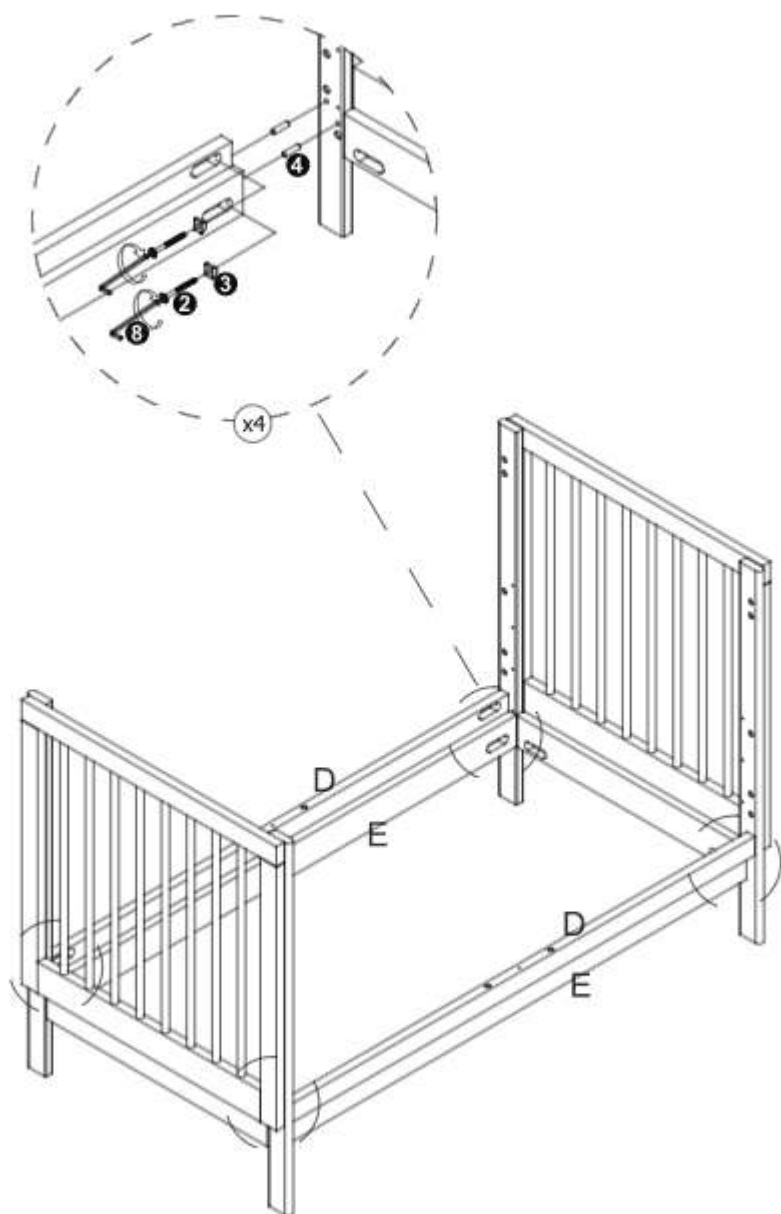

Assembly diagram

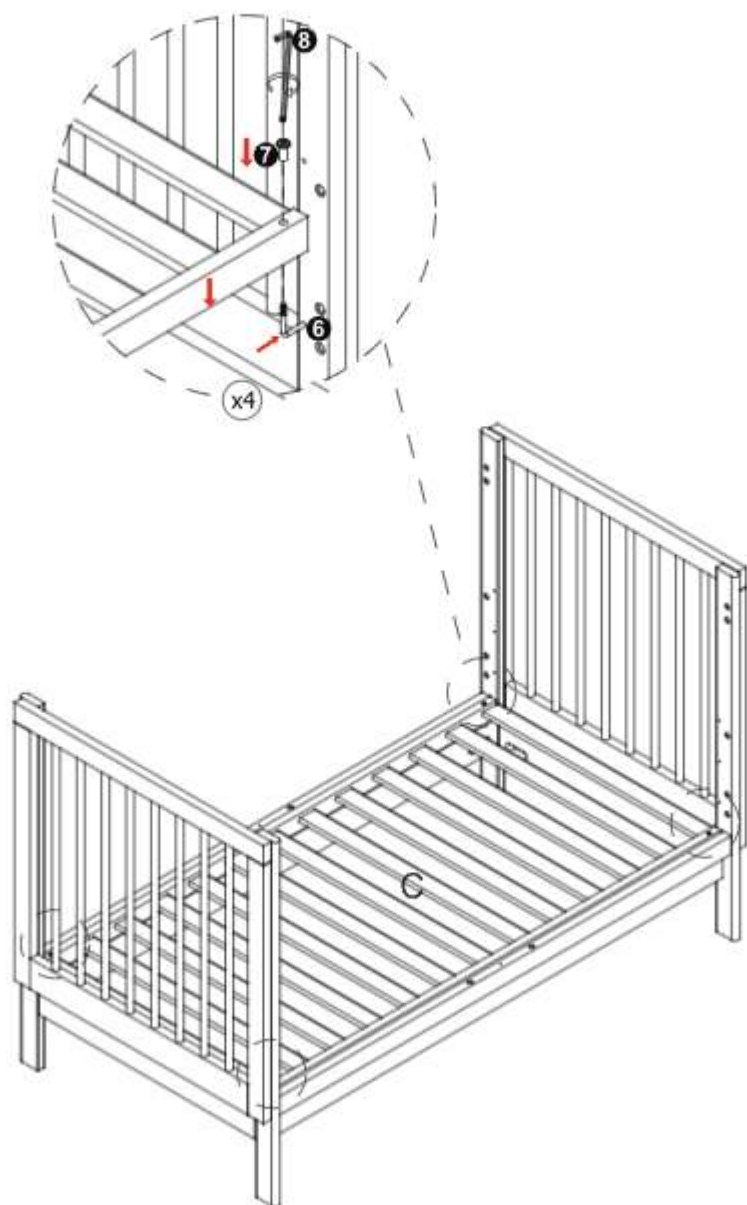

Assembly diagram



Sofa cot mode

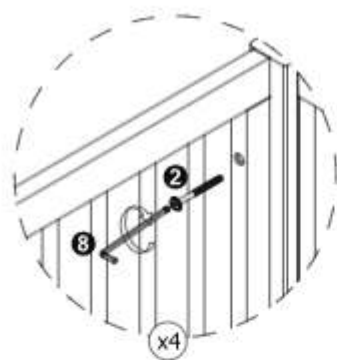

Baby cot mod

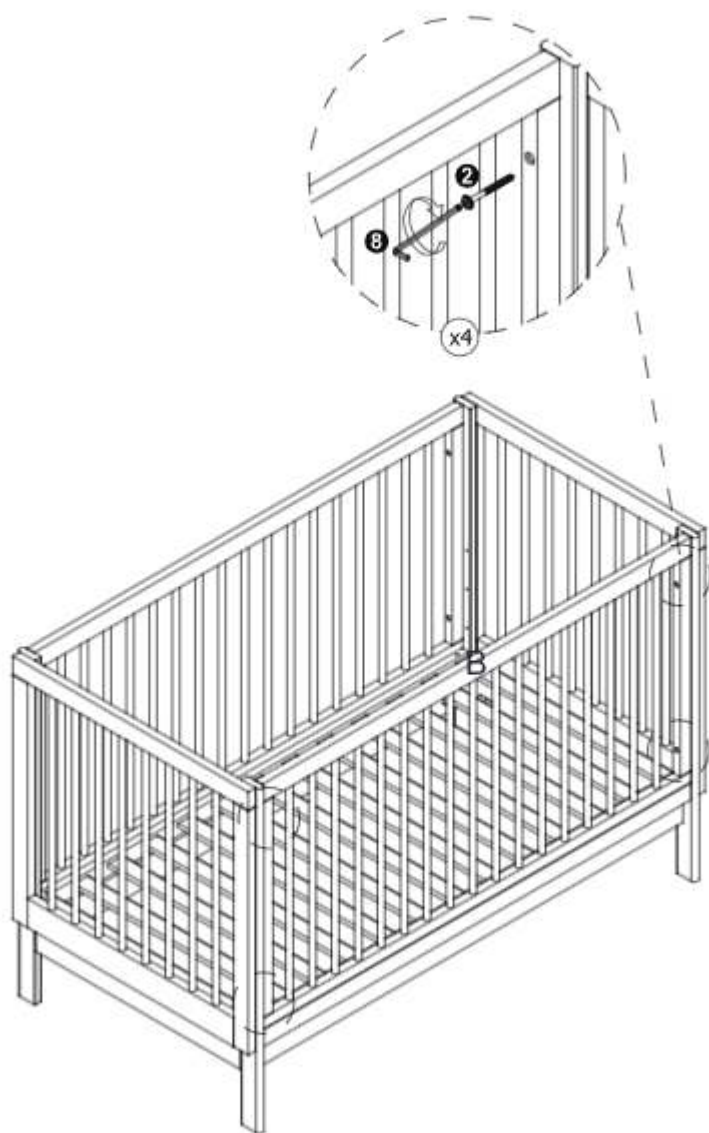

Small guardrail mode

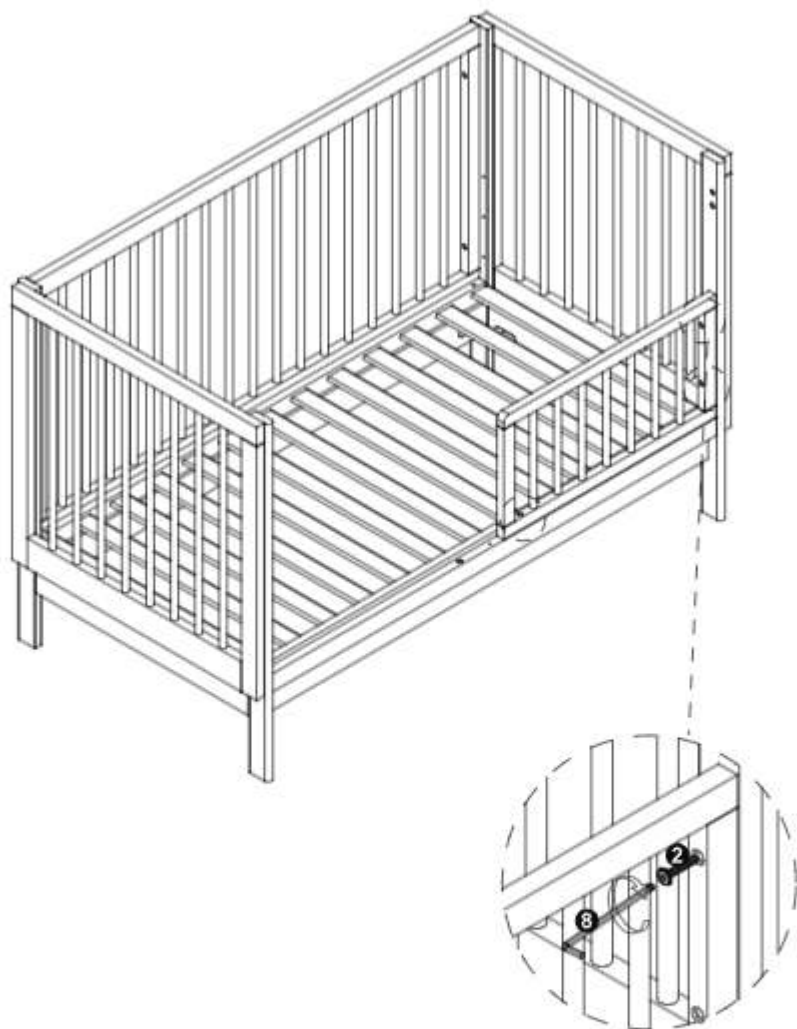

Due to variation on the styles and designs of our products, the photographs and illustrations shown in this manual are generic. Therefore products fabric, colour and design may vary from images shown, Chelino reserves the right to alter products specifications

SAFETY HINTS \ INSTRUCTIONS OF USE \ WARRANTY & GUARANTEE GUIDELINES

1. Please read this User Guide thoroughly before using this product. If you are not sure on any point in this guide please consult with the sales person whom sold you this product or contact Chelino on 0118352520. Our offices hours are Monday to Thursday from 9:00 am to 13:00 pm and 14:00 pm to 16:30 pm and Fridays from 9:00 am to 12:00 pm and 14:00 pm to 16:30 pm. Our offices are closed on Saturdays, Sundays, Public holidays and for three weeks during the December/ January festive season. We are situated at 12 Kimberlite Road, Theta Ext, Booyens Reserve, 2091, Johannesburg, Gauteng, RSA.

2. To avoid suffocation or swallowing or any other illness, please keep all packaging which have been removed from parts wrapped in the box away from infants, toddlers, children or any other living being. Please carefully dispose of the unwanted packaging once this product is fully assembled and you are satisfied with your purchase.

3. Please make sure that you are entirely satisfied with your purchase before removing the warning card attached to this product and before using this product. Once the warning card has been removed and if this product has been used we will not accept the return of this product.

4. If you are not entirely satisfied with this product purchased, please disassemble this product and re-pack it in the original packaging and return it to the store you purchased it from together with the proof of purchase. Depending on the stores policy, you will either be entitled to a replacement product, a credit voucher or a refund. This depends on the stores policies.

5. If you are not entirely satisfied with the assemble of this product or if you are not 100% sure that you have assembled this product correctly, please take this product back to the store you purchased it from and request for some assistance in checking if the assembly is correct or get this product assembled. Depending on the store's policy, there could be an extra charge for this service. Chelino will not take any responsibility if this product is incorrectly assembled thus causing any sort of injury to the user or the child. Alternatively you can contact Chelino directly on 0118352520, our offices hours are Monday to Thursday from 9:00 am to 13:00 pm and 14:00 to 16:30 pm and Fridays from 9:00 am to 12:00 pm and 14:00 pm to 16:30 pm. Our offices are closed on Saturdays, Sundays, Public holidays and for three weeks during the December/ January festive season. There is a charge for

the assembly of any product. If you require a Chelino representative to assemble this product you will have to bring this product to our offices which are situated at 12 Kimberlite Road, Theta Ext, Booyens Reserve, 2091, Johannesburg, Gauteng, RSA.

6. Please note, that any repair which will need to be made to this product must be done at the Chelino workshop which is situated at 12 Kimberlite Road, Theta Ext, Booyens Reserve, 2091, Johannesburg, Gauteng, RSA. Our offices hours are Monday to Thursday from 9:00 am to 13:00 pm and 14:00 pm to 16:30 pm and Fridays from 9:00 am to 12:00 pm and 14:00 pm to 16:30 pm. Our offices are closed on Saturdays, Sundays, Public holidays and for three weeks during the December/ January festive season. We do not provide any loan/courtesy products while your product has been sent in for repairs. Chelino requires 7 working days to repair any product, but this lead time may vary depending on the transportation of the product too and from yourself. Once the warranty card is detached from this product and once this product is used even if used once and if there is a fault, this product will need to be sent to the Chelino Workshop for the repair and no refund/credit/exchange will be allowed. Only a Chelino representative can decide whether the product needs to be replaced/credited/exchanged.

7. Once you are satisfied with the assembly of this product and have read this instruction and agree to the terms stated and are ready to use this product, please ensure that all safety locks are engaged to ensure safe use of this product.

8. Never leave the child unattended or without parent/guardian supervision while in this product, as injury could be caused by other parties intentionally or unintentionally.

9. Never lift or wheel this product while the child is in it. This can cause this product to fold and thus causing injury to the child seated in this product. When confronted with a staircase, no matter how many steps there are, please use the alternatives or remove the child from this product before using the staircase.

10. This product including rails must be fully erected prior to use. Rails must be locked in the upright position.

11. Make sure latches are secure.

12. Do not use this product if the enclosed or attached assembly cannot be strictly adhered to. Do not place cords, straps or similar items that would harm the child. Ensure that the sides are properly latched or locked in place when this product is in use.

13. Do not suspend strings over this product or attach strings to the toy bar.
14. Do not place pads or other objects inside this product that may assist the child in climbing out.
15. Do not use this product if the child is able to climb out unaided or is taller than 89cm.
16. Never allow the child to stand on the bassinette of this product. This can cause this product to fall over thus causing injury to the child. If the child is able to lift itself up drop the bassinette to the lower level.
17. Do not place this product near to a window where cords from blinds or drapes can strangle a child.
18. Do not use this product if any parts are broken, torn or missing.
19. Do not use a water mattress in this product.
20. Never use plastic bags or cellophane as a mattress cover. This can cause suffocation.
21. This product is designed for the use of only one child. This product cannot accommodate more than one child.
22. Always engage the brake when you are not using this product. Please note, by applying the brake one still cannot leave the child unattended and without parent supervision. If the brake is not engaged properly the product will move.
23. Prevent and do not allow any child to climb on to any part of this product. This imbalance of weight can cause this product to topple thus causing injury.
24. Storage compartments are there for convenience and are not suitable for holding large or heavy objects. These areas are also not waterproof or leak proof and spillage can occur.
25. If this product is provided with a mosquito net, please ensure that it is correctly fitted to avoid suffocation.
26. Chelino takes no responsibility and will not be held liable for any damage or injury caused by using this product or if this product is used for any other purposes other than its intended purpose.
27. Please note, there are no warranties or guarantee on any fabric or on the mobile units of this product.

Dimension Info

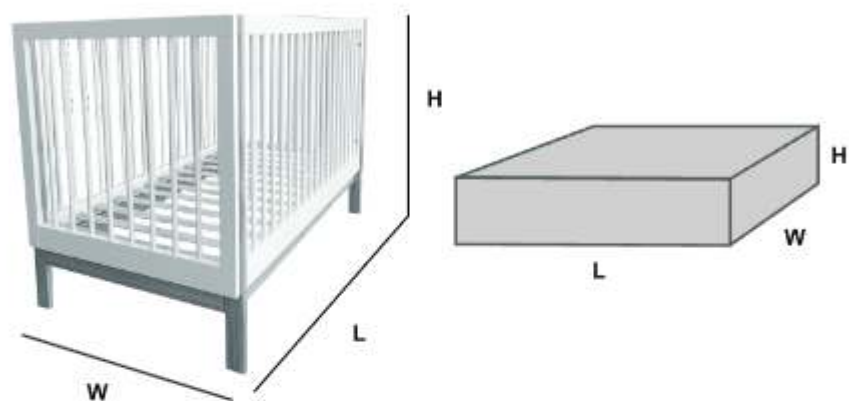

LENGTH	136.4 CM	CARTON LENGTH	137.5 CM
WIDTH	72.5 CM	CARTON WIDTH	76.5 CM
HEIGHT	89 CM	CARTON HEIGHT	16.5 CM

WEIGHT	18.5 KGS
--------	----------

ChelinoBaby®

Stores: ChelinoBaby – Ormonde – JHB
ChelinoBaby – Fourways – JHB
ChelinoBaby – Woodmead Square – JHB
ChelinoBaby – Greenstone – JHB
ChelinoBaby – Centurion – Pretoria
ChelinoBaby – Menlyn – Pretoria
ChelinoBaby – Kolonnade – Pretoria
ChelinoBaby – Gateway – Durban
ChelinoBaby – Cavendish Square – Cape Town
ChelinoBaby – Nelspruit - Mpumalanga
ChelinoBaby – Online – www.chelinobaby.co.za



Imported for :

ChelinoBaby Group of Companies.

No. 12 Kimberlite Road , Theta Ext 5 ,
Booyens Reserve , JHB , 2091. SA.

Tel: +2711 8352520

Info: info@chelinoplatinum.co.za