



## **DUET(SIDE BY SIDE) INSTRUCTION MANUAL**



Please familiarise yourself with this product prior to assembling and using it. Read and follow this instruction manual carefully to avoid injury to baby and yourself. Please store this instruction manual in a safe place for future reference.

CHELINOBABY GROUP OF COMPANIES.  
NO. 12 KIMBERLITE ROAD, THETA EXT 5,  
BOOYSENS RESERVE, JHB, 2091.SA.  
Tel: +2711 8352520

[www.chelinobaby.co.za](http://www.chelinobaby.co.za)



## NAME OF PARTS

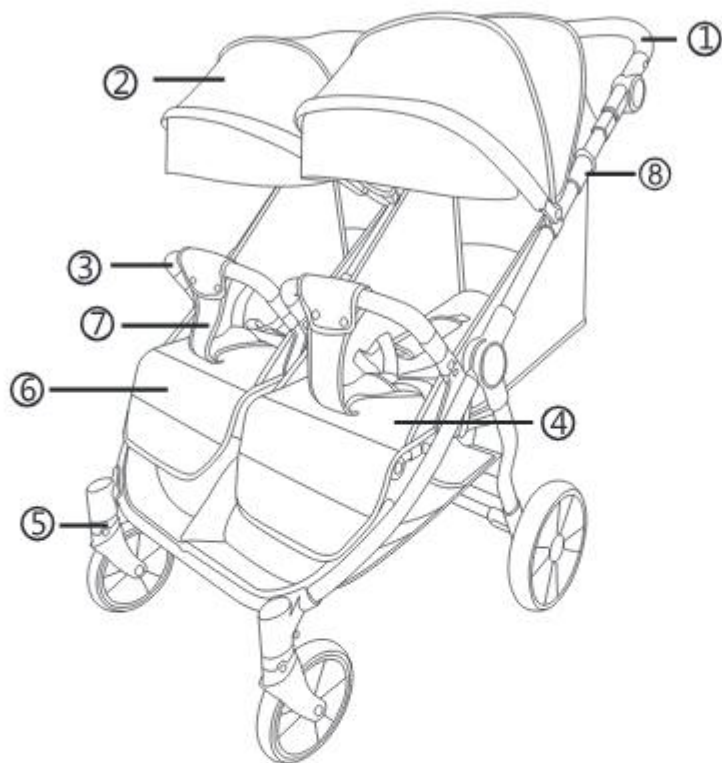

① HANDLE

⑤ FRONT WHEEL ORIENTATION

② CANOPY

⑥ ADJUSTABLE FOOTREST

③ REMOVAL FRONT BAR

⑦ SAFETY BELT

④ PADDED SEAT

⑧ FOLDING BUTTONS

## THE ASSEMBLY OF STROLLER

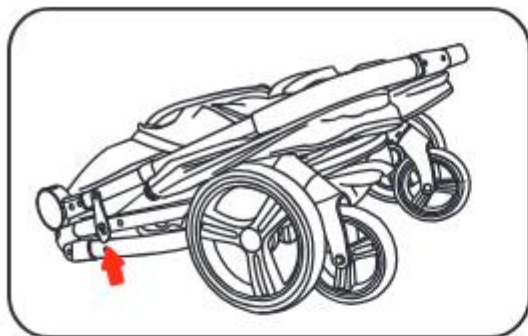

Open the hook and pull the handle up until the stroller opened absolutely as showed in picture.

### The Assembly of Front Wheel

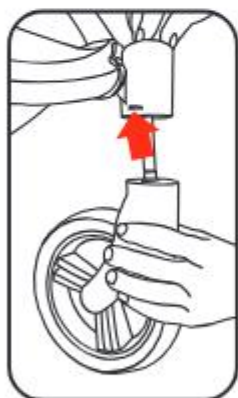

Lift the front wheel (As Shown in Figure). The opens of two front wheel bases are aligned to do the front foot, then hear the "click", which means that it has been in place. Press the detachable button in bottom of the front wheel and at the same time set aside the front wheels, you can detach.

Detachable Wheel Button



**Caution:** Ensure that all locks are in lock up position before pulling up and pushing the baby stroller.

## The Assembly and Disassembly of rear wheel

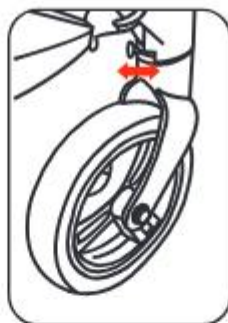
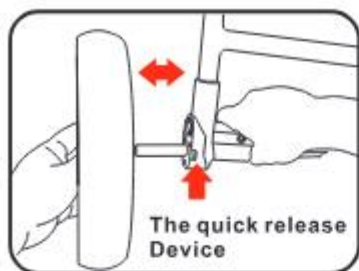

Pull the fixation part right and left to lock and unlock the front wheels.

The Assembly of rear wheel: press down the button of the quick release button, push the rear wheel part into the hole until it locks.

The disassembly of rear wheel: press down the button of the quick release button, pull out the wheel.

## Safety Belt

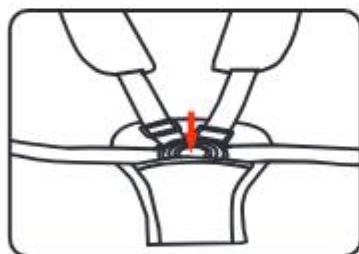

Follow the left picture: Press down the button to open the safety buckle.

Follow the right picture: Insert the buckle to the socket, when hear click sound, then it's locked.



Caution: Please always use the safety harness for safety.

Put the crotch strap between baby's legs and clasp the buckle.

## Backrest instruction



Pull up the adjustable  
backrest 170°



Caution: Adjust the beckrest carefully when baby sit in.

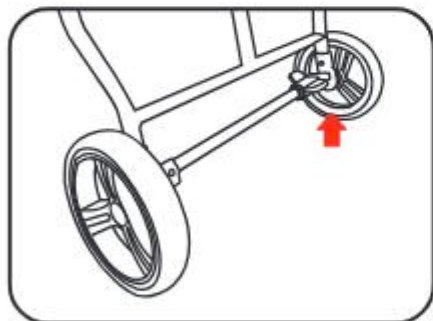

Linked Brake Footrest of  
the Rear Wheels



Caution : Please press the brake lever when stopping  
the stroller to avoid moving of the stroller.  
Push the stroller to check whether the locks  
are in lock up position

Two styles capony for winter and summer

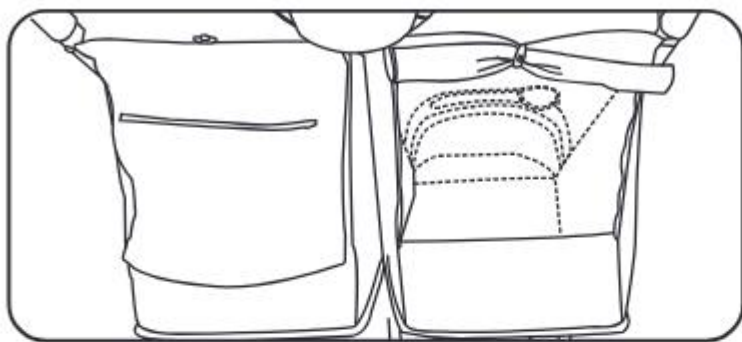

Turp up two sides as arrowed direction on left picture,fasten with button on right picture.

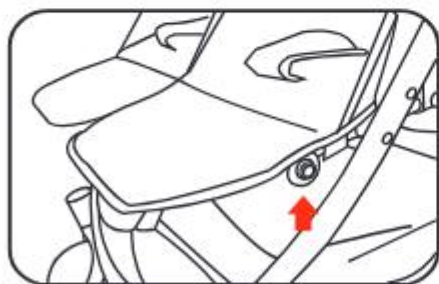

Adjustable footrest

## FOLDING OF THE STROLLER



1. Pull back canopy as picture.

2. Follow the picture ②, both hands pull folding parts and the handle at the same time

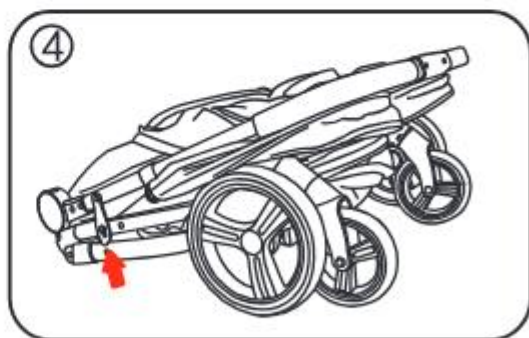
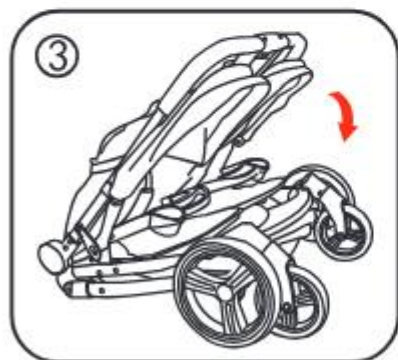

Follow the picture 3, press down the handle at the same time

Follow the picture 4, finally lock the hook on the side.

## DIMENSION INFO



---

<b>LENGTH</b>	<b>88.5 CM</b>	<b>FOLDED LENGTH</b>	<b>73.5 CM</b>
<b>WIDTH</b>	<b>78.5 CM</b>	<b>FOLDED WIDTH</b>	<b>78.5 CM</b>
<b>HEIGHT</b>	<b>101 CM</b>	<b>FOLDED HEIGHT</b>	<b>36 CM</b>

---

<b>WEIGHT</b>	<b>11.5 KGS</b>
---------------	-----------------



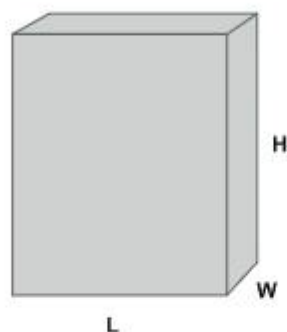

---

<b>CARTON LENGTH</b>	<b>75 CM</b>
<b>CARTON WIDTH</b>	<b>19 CM</b>
<b>CARTON HEIGHT</b>	<b>74.5 CM</b>

---

Due to variation on the styles and designs of our products, the photographs and illustrations shown in this manual are generic. Therefore products fabric, colour and design may vary from images shown, Chelino reserves the right to alter products specifications

## Knowledge of Maintenance

To avoid your baby from accidental injury, please check the stroller and do maintenance often.

1. When you open or fold the stroller, if it is out of nimbleness, please find the reason carefully, operate according to the instruction book to avoid unnecessary damage.
2. When you clean the seat, please do not soak in the water. You should use cleaning tools like a brush, clean the blot softly.
3. Please check often if there is any loose parts, spare parts broken or not, sewing fracture or not. If necessary, please change those broken parts.

## **WARNING**

1. This stroller is intended for child from birth up 15KGS.
2. The maximum loading carried in the basket must never exceed 3 KGS.
3. It may be dangerous to leave your child unattended. You are personally responsible for your child's safety.
4. Check that the pram body or seat unit or car seat attachment devices are correctly engaged before use.
5. Any load attached to the handle and/or on the back of the backrest and/or on the sides of the vehicle will affect the stability of the vehicle.
6. Prevent your child from falling and sliding out. Always use the restraint system.
7. This stroller isn't suitable for running or skating.
8. Do not lift and carry the stroller while your child is seated.
9. Do not use accessories that haven't been approved by supplier or seller.
10. Do not allow your child to stand in the stroller.
11. Never let stroller be used in step slope, stairs, escalator, sand beach, rough roads, mud, etc.
12. Always used the brakes when parking the stroller.
13. Do not let the stroller nearby fire.
14. The stroller is suitable for the child from 0month to 36 months.
15. Child may slip into leg openings and strangle.  
Never use in reclined carriage position(s) unless  
(manufacturer to insert product specific instructions).
16. Never leave the child unattended.
17. Excessive weight may cause a hazardous unstable condition to exist.
18. This product is in conformity with standard EN 1888-1:2018(E)
19. To avoid injury ensure that the child is kept away when unfolding and folding this product.
20. Do not let the child play with this product.
21. Please use the most reclined position for new born babies.
22. Any accessories which are not approved by the manufacturer shall not be used.
23. Only replacement parts supplied or recommended by the manufacture shall be used.

## SAFETY HINTS\INSTRUCTIONS OF USE \ WARRANTY & GAURANTEE GUIDELINES

1. Please read this User Guide thoroughly before using this product. If you are not sure on any point in this guide please consult with the sales person whom sold you this product or contact Chelino on 0118352520. Our offices hours are Monday to Thursday from 9:00 am to 13:00 pm and 14:00 pm to 16:30 pm and Fridays from 9:00 am to 12:00 pm and 14:00 pm to 16:30 pm. Our offices are closed on Saturdays, Sundays, Public holidays and for three weeks during the December/ January festive season. We are situated at 12 Kimberlite Road, Theta Ext, Booyens Reserve, 2091, Johannesburg, Gauteng, RSA.
2. To avoid suffocation or swallowing or any other illness, please keep all packaging which have been removed from parts wrapped in the box away from infants, toddlers, children or any other living being. Please carefully dispose of the unwanted packaging once this product is fully assembled and you are satisfied with your purchase.
3. Please make sure that you are entirely satisfied with your purchase before removing the warning card attached to this product and before using this product. Once the warning card has been removed and if this product has been used we will not accept the return of this product.
4. If you are not entirely satisfied with this product purchased, please disassemble this product and re-pack it in the original packaging and return it to the store you purchased it from together with the proof of purchase. Depending on the stores policy, you will either be entitled to a replacement product, a credit voucher or a refund. This depends on the stores policies.
5. If you are not entirely satisfied with the assemble of this product or if you are not 100% sure that you have assembled this product correctly, please take this product back to the store you purchased it from and request for some assistance in checking if the assembly is correct or get this product assembled. Depending on the store's policy, there could be an extra charge for this service. Chelino will not take any responsibility if this product is incorrectly assembled thus causing any sort of injury to the user or the child. Alternatively you can contact Chelino directly on 0118352520, our offices hours are Monday to Thursday from 9:00 am to 13:00 pm and 14:00 to 16:30 pm and Fridays from 9:00 am to 12:00 pm and 14:00 pm to 16:30 pm. Our offices are closed on Saturdays, Sundays, Public holidays and for three weeks during the December/ January festive season. There is a charge for the assembly of any product. If you require a Chelino representative to assemble this product you will have to bring this product to our offices which are situated at 12 Kimberlite Road, Theta Ext, Booyens Reserve, 2091, Johannesburg, Gauteng, RSA.

6. Please note, that any repair which will need to be made to this product must be done at the Chelino workshop which is situated at 12 Kimberlite Road, Theta Ext, Booyens Reserve, 2091, Johannesburg, Gauteng, RSA. Our offices hours are Monday to Thursday from 9:00 am to 13:00 pm and 14:00 pm to 16:30 pm and Fridays from 9:00 am to 12:00 pm and 14:00 pm to 16:30 pm. Our offices are closed on Saturdays, Sundays, Public holidays and for three weeks during the December/ January festive season. We do not provide any loan/courtesy products while your product has been sent in for repairs. Chelino requires 7 working days to repair any product, but this lead time may vary depending on the transportation of the product too and from yourself. Once the warranty card is detached from this product and once this product is used even if used once and if there is a fault, this product will need to be sent to the Chelino Workshop for the repair and no refund/credit/exchange will be allowed. Only a Chelino representative can decide whether the product needs to be replaced/credited/exchanged.

7. Once you are satisfied with the assembly of this product and have read this instruction and agree to the terms stated and are ready to use this product, please ensure that all safety locks are engaged to ensure safe use of this product.

8. Please ensure that the child is always securely strapped into this product at all times. The seat belts must be properly adjusted to keep the child secured. If the seat belt is too loose the child could fall out thus causing injury. If the seat belts are too tight it will cause injury and aggravation to the child.

9. Never leave the child unattended or without parent/guardian supervision while in this product, as injury could be caused by other parties intentionally or unintentionally. This product can be knocked over and the child can be injured.

10. Never lift this product while the child is in it. This can cause this product to fold and thus causing injury to the child seated in this product. When confronted with a staircase, no matter how many steps there are, please use the alternatives such as an elevator/lift or ramp or remove the child from this product before using the staircase.

11. Never allow the child to stand on the seat of this product. This can cause this product to fold and thus causing injury to the child. The child can also fall out of this product causing injury to him/herself. This can also cause damage to structure of this product.

12. This product is designed for the use of only one child. This product cannot accommodate more than one child.

13. Always engage the brake when you are not using this product. Please note, by applying the brake one still cannot leave the child unattended and without parent supervision. If the brake is not engaged properly the product will move.

14. Take special care when adjusting the backrest if the child is seated in this product. It is preferred to select the desired backrest position before seating the child in this product.

15. Prevent and do not allow any child to climb into this product or hang onto the handle bars or any other part of this product. This imbalance of weight can cause this product to topple thus causing injury.

16. Do not hang or place any diaper bag or shopping bags or any other item over the handle bars or canopy of this product. This weight can cause damage to this product and also cause this product to fold or topple.

17. Storage trays\storage compartments\cup holders are there for convenience and are not suitable for holding large amounts of liquids (hot or cold) or heavy objects. These areas are also not waterproof or leak proof and spillage can occur.

18. The storage basket situated underneath the seat can hold a maximum weight of 2kgs. Do not place any items heavier than 3kgs and items which do not fit in this basket as this will hamper the performance of this product.

19. This product is fit to carry a child weighing no more than 15kgs.

20. This product was designed to be used on smooth surfaces and in average weather climates. Do not use this product on rough terrains and uneven surfaces and in extreme weather conditions. Using this product in the undesired terrains and weather conditions can cause serious damage to this product and to your child.

21. Chelino takes no responsibility and will not be held liable for any damage or injury caused by using this product or if this product is used for any other purposes other than its intended purpose.

22. Please note, there are no warranties or guarantee on any fabrics or sponge grip handles used on this product.

# ChelinoBaby®

Stores: ChelinoBaby – Ormonde – JHB  
ChelinoBaby – Fourways – JHB  
ChelinoBaby – Woodmead Square – JHB  
ChelinoBaby – Greenstone – JHB  
ChelinoBaby – Centurion – Pretoria  
ChelinoBaby – Menlyn – Pretoria  
ChelinoBaby – Kolonnade – Pretoria  
ChelinoBaby – Gateway – Durban  
ChelinoBaby – Cavendish Square – Cape Town  
ChelinoBaby – Nelspruit – Mpumalanga  
ChelinoBaby – Online – [www.chelinobaby.co.za](http://www.chelinobaby.co.za)



Imported for :

ChelinoBaby Group of Companies.

No. 12 Kimberlite Road , Theta Ext 5 ,  
Booyens Reserve , JHB , 2091. SA.

Tel: +2711 8352520

Info: [info@chelino.co.za](mailto:info@chelino.co.za)