

Chelino



ONIDA FLEX II TRAVEL SYSTEM

CHELINOBABY GROUP OF COMPANIES.

NO. 12 KIMBERLITE ROAD, THETA EXT 5, BOOYSENS RESERVE, JHB, 2091.SA.

Tel: +2711 8352520

www.chelinobaby.co.za



WARNING

PLEASE READ THESE INSTRUCTIONS CAREFULLY TO ENSURE THE SAFETY OF YOUR CHILD.







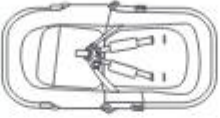

1. Read all instructions before assembling and using product. Failure to follow all warnings and instructions may result in serious injury or death.
2. Keep Instructions for future use.
3. **NEVER LEAVE CHILD UNATTENDED. ALWAYS** keep child in view when in stroller.
4. Adult assembly required.
5. Always ensure that all components are correctly fitted and fixed.
6. Unit may become unstable if manufacturer's recommended load is exceeded, or if parcel bag or accessory other than that recommended by the manufacturer is used or hung from the unit.
7. Children and adults should be clear of moving parts while making stroller adjustments. Damage to fingers or extremities may occur when opening or closing the frame.
8. This toddler seat is suitable for children from newborn up to 49lbs/22 kg.
9. Suitable from birth in bassinet mode up to a maximum weight of 20 lbs or until the child can sit up unaided, roll over or push itself up on its hands and knees.
10. **ALWAYS** use the stroller in the fully reclined position for babies who have not yet developed good head and neck control.
11. The restraint system must be used at all times.
12. Maximum weight for the storage basket is 11 lbs/5 kg
13. Maximum weight for the cup holder is 1 lb/0.5 kg.
14. This product is not suitable for running or skating.
15. **DO NOT** use with more than one child in the seat at a time
16. **DO NOT** carry or lift the stroller with child in it
17. **DO NOT** use the basket as a child or pet carrier
18. Keep Away from fire. **DO NOT** use this product near an open fire or exposed flame.
19. The brake must be locked while taking the child in or out of the stroller, and when parked.
20. **DO NOT** use the stroller if any part is damaged, broken, torn or missing. Use only replacement parts and accessories supplied and approved by the manufacturer.

FEATURES

- Convertible to pushchair / bassinet in minutes
- Lightweight aluminum frame and premium fabric
- Reversible seat and bassinet from parent-facing to forward-facing modes .
- Adjustable seat recline, designed to provide sit and recline position
- Adjustable handlebar, designed for parents in different height
- Peek-A-Boo canopy window to keep an eye on your baby
- 5-point safety harness
- Detachable bumper bar
- Ideal cup holder for keep drinks or nursing bottle
- A large seat area and storage basket
- Suspension wheels to provide your baby a smooth ride. 360° rotated and lockable front wheels.
- One-link brake
- Easy to fold and Compact folding
- Fit with infant carrier
- Comply with European Standard EN 1888-2: 2018+A1: 2022

Due to variation on the styles and designs of our products, the photographs and illustrations shown in this manual are generic. Therefore products fabric, colour and design may vary from images shown, Chelino reserves the right to alter products specifications.

Parts

<p>1</p>  <p>Frame & basket</p>	<p>2</p>  <p>Seat & harness covers</p>	<p>3</p>  <p>Canopy</p>
<p>4</p>  <p>Bumper bar</p>	<p>5</p>  <p>2x Rear wheels</p>	<p>6</p>  <p>2x Front swivel wheels</p>
<p>7</p>  <p>Cup holder</p>	<p>8</p>  <p>Car seat adapter</p>	<p>9</p>  <p>Optional infant Carrier</p>

Assembly

Step 1 - Frame assembly

Release the storage latch. To unfold the stroller, simultaneously lift handle and pull up with a swift motion until an audible 'click' is heard. This will ensure the locking mechanism has engaged.

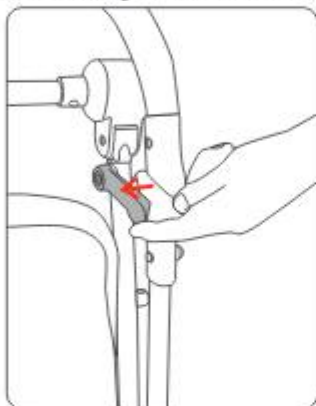

Fig.1



Fig.2

Step 2 - Wheel assembly

Front Wheel Assembly- Align the shaft on the wheel with the hole in the front leg and push in. Listen for a 'click'.



Fig.1

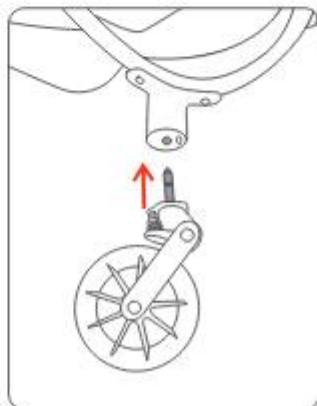

Fig.2

Rear Wheel Assembly - push each wheel pin into the sides of the brake bar until you hear a "click". Give them a tug to ensure they are attached securely.

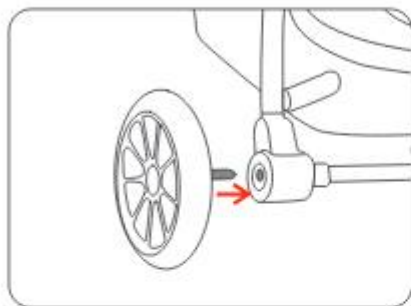

Fig.3



Fig.4

Step 3 - Seat assembly

Align the seat with the frame and push downwards, listening for a 'click' to lock in place.

The footrest is in same direction as front wheels.

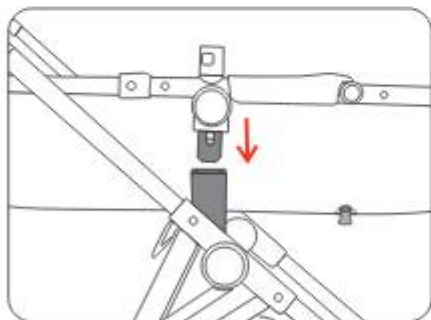

Fig.1



Fig.2

Step 4- Canopy assembly

Align the two canopy plastic slides with the two seat slides and simultaneously push towards the centre as shown.

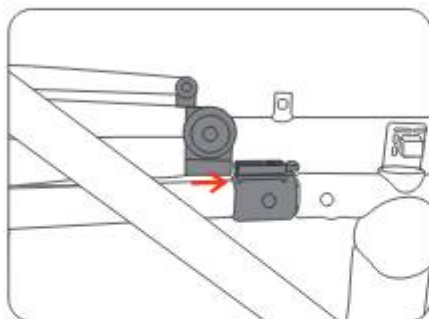

Fig.1



Fig.2

Step 5- Attaching bumper bar

Align bumper bar shaft with the hole in the frame and push in. Listen for the 'click', then repeat on the other side.

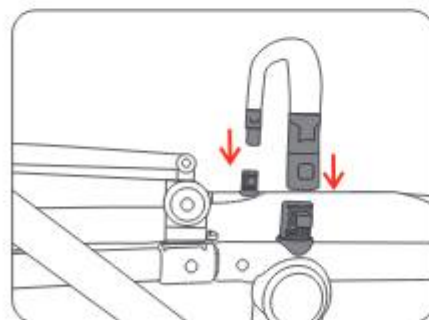

Fig.1



Fig.2

OPERATING

1. Operating front swivel lock

To lock, push the swivel locks outwards. To unlock, push the swivel locks inwards.

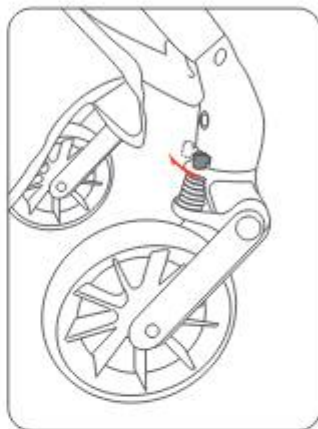

Fig.1

2. Operating brakes

To apply the brake, press down firmly on the brake lever. To release the brake, press the brake lever upwards.

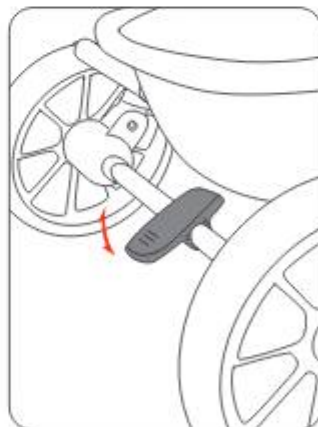

Fig.1

3. Adjusting the handlebar

Press the buttons on two sides of handlebar, to lift or press into three-position adjustable.

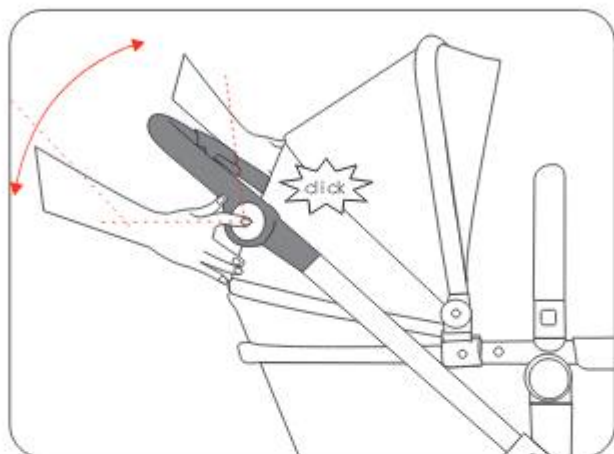

Fig.1

4. Convert bassinet to seat

The backrest can be adjusted by tightening the adjustable belt under the sleeping basket into a sitting position, half reclining or sleeping mode to meet the different requirements of your baby.

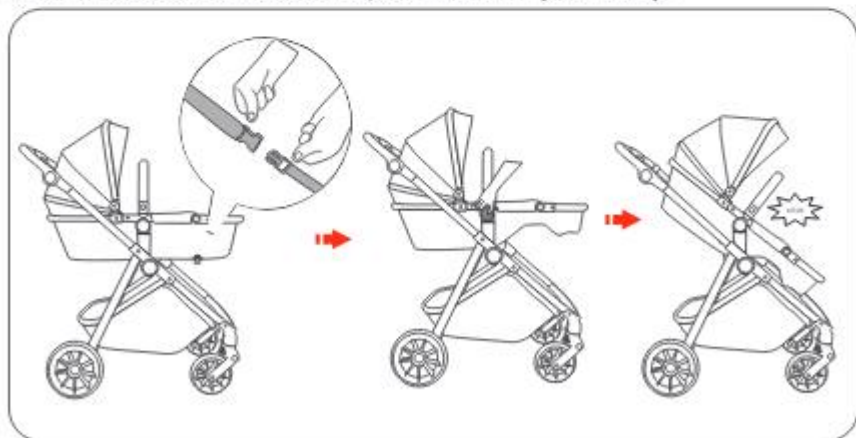

Fig.1

5. Adjusting seat recline

Squeeze adjuster clip and pull in a upwards or downwards motion to adjust backrest position.

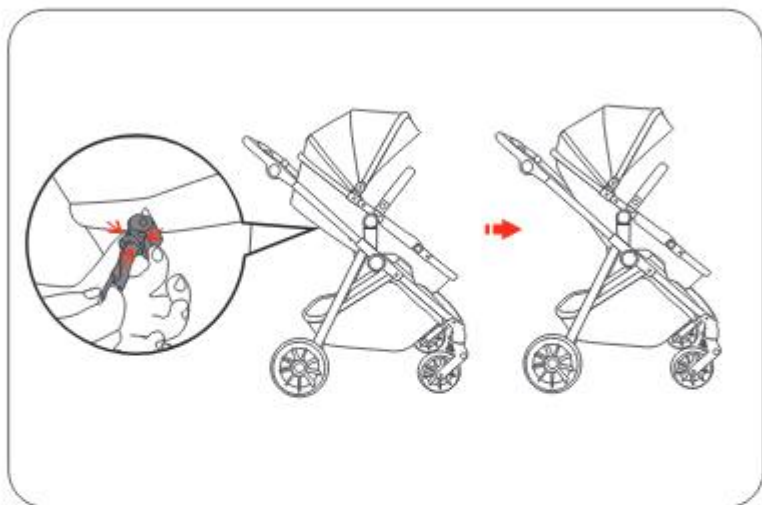

Fig.1

6. Adjusting canopy

To use the canopy, pull the front edge forward to open. There is a peek-a-boo window for parents to watch baby. Four-position adjustable.

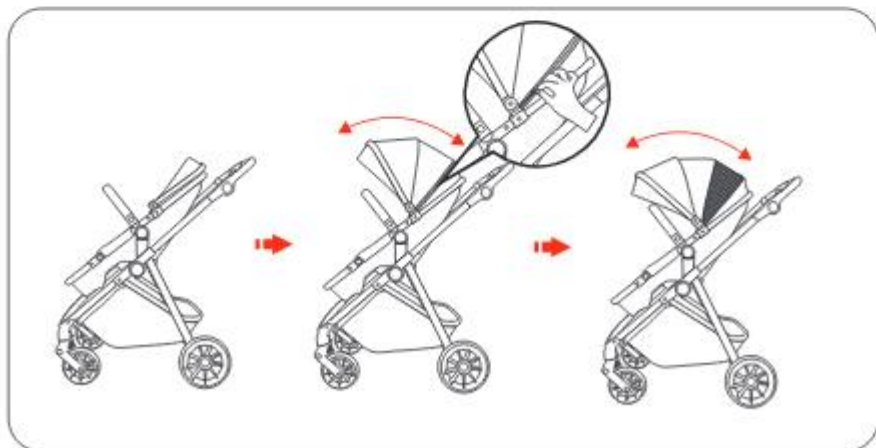

Fig.1

7. Adjusting footrest

Press the buttons on two sides of footrest, to lift or press into three-position adjustable.

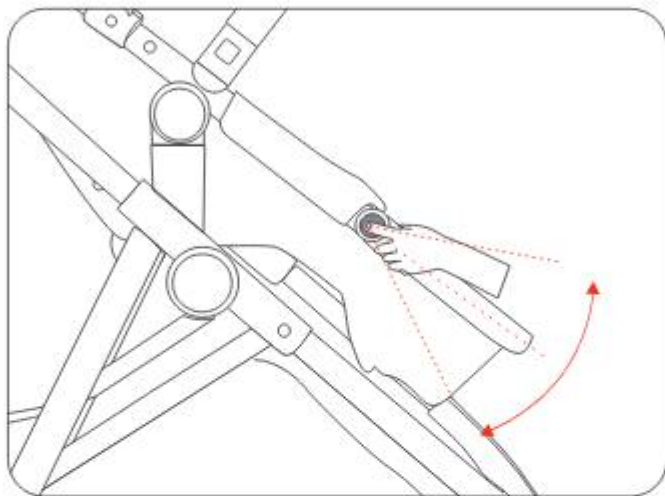

Fig.1

8. Put your cup

Attach the cup holder to the frame and put your cup into it.

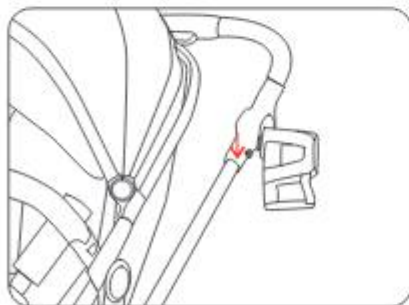

Fig.1

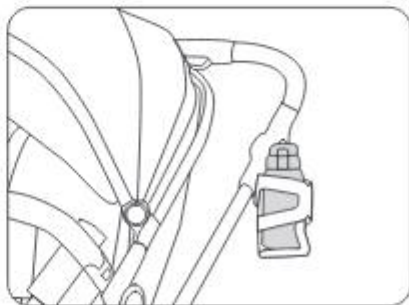

Fig.2

9. Securing your child

Attach each of the 4 harness straps into the central buckle. To tighten or loosen the waist and/or shoulder straps, hold and lift the plastic adjuster. Adjust straps to desired position. The waist strap needs to fit firmly around the child.

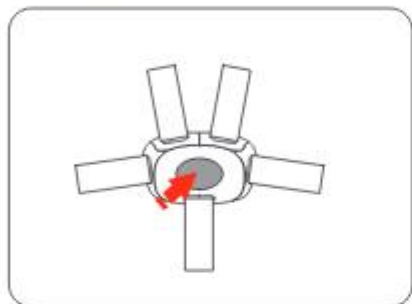

Fig.1

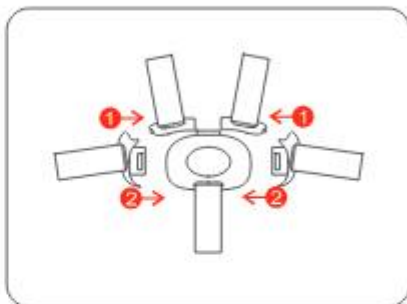

Fig.2

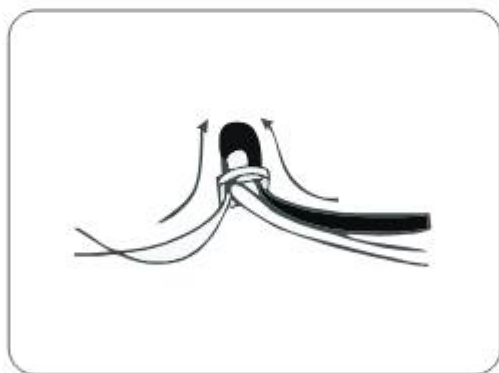

Fig.3

Always engage the brake before placing your child in the stroller.

10. Folding stroller

Remove the stroller seat by lifting the release levers on either side. Push the two buttons on the handlebar and meanwhile push down the handlebar to close the frame.

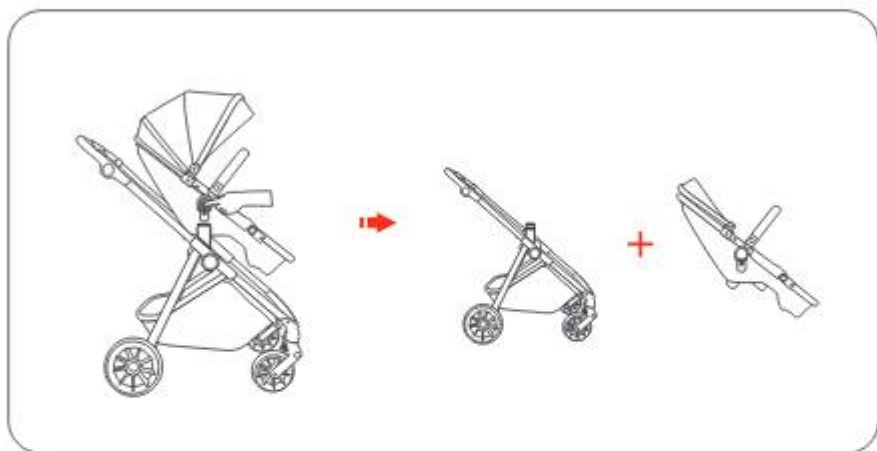

Fig.1

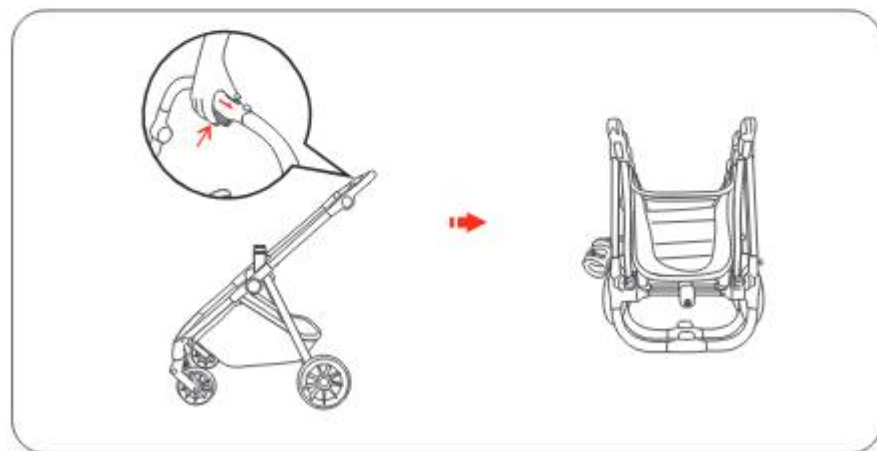
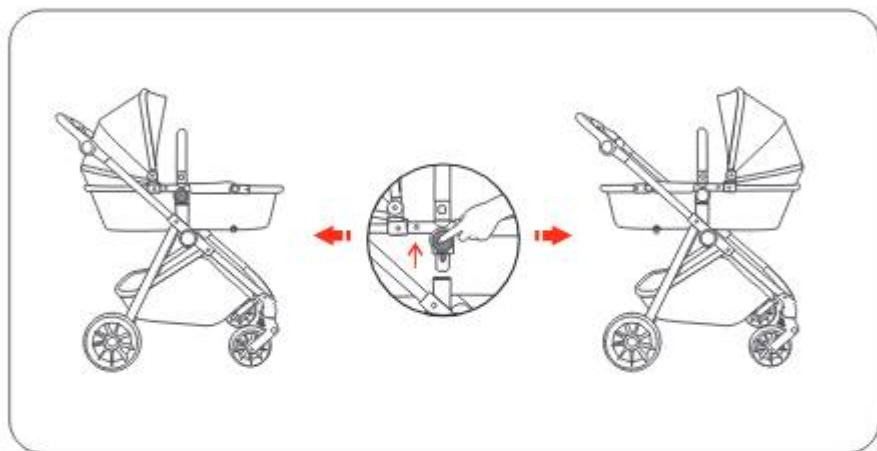

Fig.2

Tips 1 : Reverse seat direction

Press the seat release buttons on both sides and lift the seat . Turn the stroller seat around and align with the frame and gently push down. Listen for 'click' to lock in place.



Tips 2: Reverse bassinet direction

Press the seat release buttons on both sides and lift the seat . Turn the stroller seat around and align with the frame and gently push down. Listen for 'click' to lock in place.

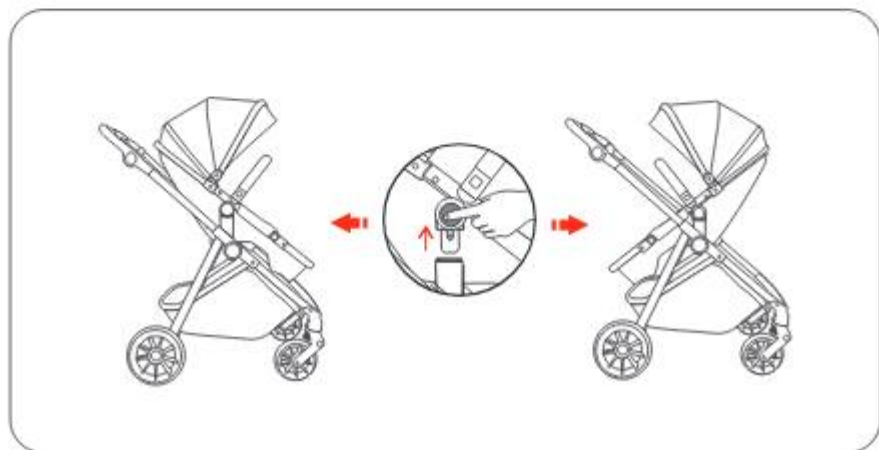

Tips 3: Fit with infant carrier

Insert the adapters into carrier joint. Align the adapters and stroller frame the push down until a "click" heard.



Fig.1

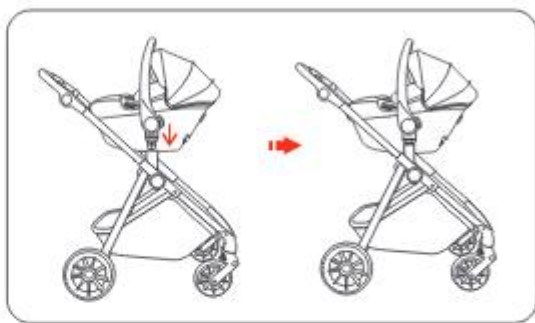
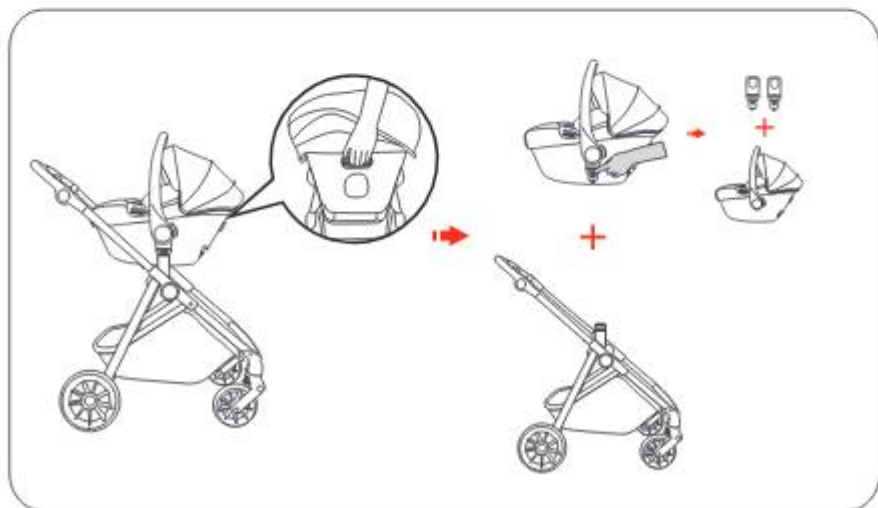

Fig.2

Lift the lever release on the back to take out the carrier. Remove the adapters.



Care And Maintenance

- Always store in a clean and dry place.
- Clean the frame by wiping with a damp cloth.
- Do not use abrasives, bleach or strong detergents.
- Spot clean fabrics with warm water and mild soap.
- Ensure fabric is dry before storing.
- Regularly check for loose parts and tighten when required.
- Damaged or broken parts should be immediately replaced.
- Do not allow children to stand on the axle/brake bar between the wheels. This is unsafe and could damage the stroller.

SAFETY HINTS\INSTRUCTIONS OF USE \ WARRANTY & GUARANTEE GUIDELINES

1.Please read this User Guide thoroughly before using this product. If you are not sure on any point in this guide please consult with the sales person whom sold you this product or contact Chelino on 0118352520. Our offices hours are Monday to Thursday from 9:00 am to 13:00 pm and 14:00 pm to 16:30 pm and Fridays from 9:00 am to 12:00 pm and 14:00 pm to 16:30 pm. Our offices are closed on Saturdays, Sundays, Public holidays and for three weeks during the December/ January festive season. We are situated at 12 Kimberlite Road, Theta Ext, Boosens Reserve, 2091, Johannesburg, Gauteng, RSA.

2.To avoid suffocation or swallowing or any other illness, please keep all packaging which have been removed from parts wrapped in the box away from infants, toddlers, children or any other living being. Please carefully dispose of the unwanted packaging once this product is fully assembled and you are satisfied with your purchase.

3.Please make sure that you are entirely satisfied with your purchase before removing the warning card attached to this product and before using this product. Once the warning card has been removed and if this product has been used we will not accept the return of this product.

4.If you are not entirely satisfied with this product purchased, please disassemble this product and re-pack it in the original packaging and return it to the store you purchased it from together with the proof of purchase. Depending on the stores policy, you will either be entitled to a replacement product, a credit voucher or a refund. This depends on the stores policies.

5.If you are not entirely satisfied with the assemble of this product or if you are not 100% sure that you have assembled this product correctly, please take this product back to the store you purchased it from and request for some assistance in checking if the assembly is correct or get this product assembled. Depending on the store's policy, there

could be an extra charge for this service. Chelino will not take any responsibility if this product is incorrectly assembled thus causing any sort of injury to the user or the child. Alternatively you can contact Chelino directly on 0118352520, our offices hours are Monday to Thursday from 9:00 am to 13:00 pm and 14:00 to 16:30 pm and Fridays from 9:00 am to 12:00 pm and 14:00 pm to 16:30 pm. Our offices are closed on Saturdays, Sundays, Public holidays and for three weeks during the December/ January festive season. There is a charge for the assembly of any product. If you require a Chelino representative to assemble this product you will have to bring this product to our offices which are situated at 12 Kimberlite Road, Theta Ext, Booysens Reserve, 2091, Johannesburg, Gauteng, RSA.

6. Please note, that any repair which will need to be made to this product must be done at the Chelino workshop which is situated at 12 Kimberlite Road, Theta Ext, Booysens Reserve, 2091, Johannesburg, Gauteng, RSA. Our offices hours are Monday to Thursday from 9:00 am to 13:00 pm and 14:00 pm to 16:30 pm and Fridays from 9:00 am to 12:00 pm and 14:00 pm to 16:30 pm. Our offices are closed on Saturdays, Sundays, Public holidays and for three weeks during the December/ January festive season. We do not provide any loan/courtesy products while your product has been sent in for repairs. Chelino requires 7 working days to repair any product, but this lead time may vary depending on the transportation of the product too and from yourself. Once the warranty card is detached from this product and once this product is used even if used once and if there is a fault, this product will need to be sent to the Chelino Workshop for the repair and no refund/credit/exchange will be allowed. Only a Chelino representative can decide whether the product needs to be replaced/credited/exchanged.

7. Once you are satisfied with the assembly of this product and have read this instruction and agree to the terms stated and are ready to use this product, please ensure that all safety locks are engaged to ensure safe use of this product.

8. Please ensure that the child is always securely strapped into this product at all times. The seat belts must be properly adjusted to keep the child secured. If the seat belt is too loose the child could fall out thus causing injury. If the seat belts are too tight it will cause injury and aggravation to the child.

9. Never leave the child unattended or without parent/guardian supervision while in this product, as injury could be caused by other parties intentionally or unintentionally. This product can be knocked over and the child can be injured.

10. Never lift this product while the child is in it. This can cause this product to fold and thus causing injury to the child seated in this product.

When confronted with a staircase, no matter how many steps there are, please use the alternatives such as an elevator\lift or ramp or remove the child from this product before using the staircase.

11.Never allow the child to stand on the seat of this product. This can cause this product to fold and thus causing injury to the child. The child can also fall out of this product causing injury to him\herself. This can also cause damage to structure of this product.

12.This product is designed for the use of only one child. This product cannot accommodate more than one child.

13.Always engage the brake when you are not using this product. Please note, by applying the brake one still cannot leave the child unattended and without parent supervision. If the brake is not engaged properly the product will move.

14.Take special care when adjusting the backrest if the child is seated in this product. It is preferred to select the desired backrest position before seating the child this product.

15.Prevent and do not allow any child to climb into this product or hang onto the handle bars or any other part of this product. This imbalance of weight can cause this product to topple thus causing injury.

16.Do not hang or place any diaper bag or shopping bags or any other item over the handle bars or canopy of this product. This weight can cause damage to this product and also cause this product to fold or topple.

17.Storage trays\storage compartments\cup holders are there for convenience and are not suitable for holding large amounts of liquids (hot or cold) or heavy objects. These areas are also not waterproof or leak proof and spillage can occur.

18.The storage basket situated underneath the seat can hold a maximum weight of 5kgs. Do not place any items heavy than 5kgs and items which do not fit in this basket as this will hamper the performance of this product.

19.This product is fit to carry a child weighing no more than 22kgs.

20.This product was designed to be used on smooth surfaces and in average weather climates. Do not use this product on rough terrains and uneven surfaces and in extreme weather conditions. Using this product in the undesired terrains and weather conditions can cause serious damage to this product and to your child.

21.Chelino takes no responsibility and will not be held liable for any damage or injury caused by using this product or if this product is used for any other purposes other than its intended purpose.

22.Please note, there are no warranties or guarantee on any fabrics or sponge grip handles used on this product.

Dimension Info



LENGTH	98 CM	FOLDABLE LENGTH	88 CM
WIDTH	45 CM	FOLDABLE WIDTH	55.5 CM
HEIGHT	103.5 CM	FOLDABLE HEIGHT	45 CM

WEIGHT 9 KGS

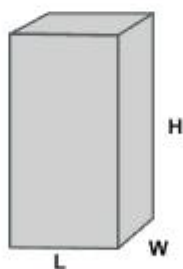

CARTON LENGTH	48 CM
CARTON WIDTH	29 CM
CARTON HEIGHT	75 CM

ChelinoBaby®

Stores: ChelinoBaby – Ormonde – JHB
ChelinoBaby – Fourways – JHB
ChelinoBaby – Woodmead Square – JHB
ChelinoBaby – Greenstone – JHB
ChelinoBaby – Centurion – Pretoria
ChelinoBaby – Menlyn – Pretoria
ChelinoBaby – Kolonnade – Pretoria
ChelinoBaby – Gateway – Durban
ChelinoBaby – Cavendish Square – Cape Town
ChelinoBaby – Nelspruit – Mpumalanga
ChelinoBaby – Online – www.chelinobaby.co.za



Imported for :

ChelinoBaby Group of Companies.

No. 12 Kimberlite Road , Theta Ext 5 ,
Booyens Reserve , JHB , 2091. SA.

Tel: +2711 8352520

Info: info@chelino.co.za